

Датчики (зонды) радиометрические DELTA OHM LPPAR04BL

Технические характеристики

Архангельск (8182)63-90-72	Ижевск (3412)26-03-58	Магнитогорск (3519)55-03-13	Пермь (342)205-81-47	Сургут (3462)77-98-35
Астана (7172)727-132	Иркутск (395)279-98-46	Москва (495)268-04-70	Ростов-на-Дону (863)308-18-15	Тверь (4822)63-31-35
Астрахань (8512)99-46-04	Казань (843)206-01-48	Мурманск (8152)59-64-93	Рязань (4912)46-61-64	Томск (3822)98-41-53
Барнаул (3852)73-04-60	Калининград (4012)72-03-81	Набережные Челны (8552)20-53-41	Самара (846)206-03-16	Тула (4872)74-02-29
Белгород (4722)40-23-64	Калуга (4842)92-23-67	Нижний Новгород (831)429-08-12	Санкт-Петербург (812)309-46-40	Тюмень (3452)66-21-18
Брянск (4832)59-03-52	Кемерово (3842)65-04-62	Новокузнецк (3843)20-46-81	Саратов (845)249-38-78	Ульяновск (8422)24-23-59
Владивосток (423)249-28-31	Киров (8332)68-02-04	Новосибирск (383)227-86-73	Севастополь (8692)22-31-93	Уфа (347)229-48-12
Волгоград (844)278-03-48	Краснодар (861)203-40-90	Омск (3812)21-46-40	Симферополь (3652)67-13-56	Хабаровск (4212)92-98-04
Вологда (8172)26-41-59	Красноярск (391)204-63-61	Орел (4862)44-53-42	Смоленск (4812)29-41-54	Челябинск (351)202-03-61
Воронеж (473)204-51-73	Курск (4712)77-13-04	Оренбург (3532)37-68-04	Сочи (862)225-72-31	Череповец (8202)49-02-64
Екатеринбург (343)384-55-89	Липецк (4742)52-20-81	Пенза (8412)22-31-16	Ставрополь (8652)20-65-13	Ярославль (4852)69-52-93
Иваново (4932)77-34-06	Киргизия (996)312-96-26-47	Казахстан (772)734-952-31	Таджикистан (992)427-82-92-69	

Единый адрес для всех регионов: dmh@nt-rt.ru || www.deltaohm.nt-rt.ru

LPPAR04BL

Introduction

The *LP PAR 04 BL* measures photosynthetically active radiation (P_A_R) in the 400nm-700nm spectral region. The unit of PAR is micromoles (photons) per second per square meter [$(\mu\text{mol (phot)})/(\text{s m}^2)$]. The special geometry of the diffuser allows radiometer to have a field of view of 180° according to cosine law.

The LP PAR 04 BL is provided with base and level that allowed easy mounting and positioning (Figure 1).

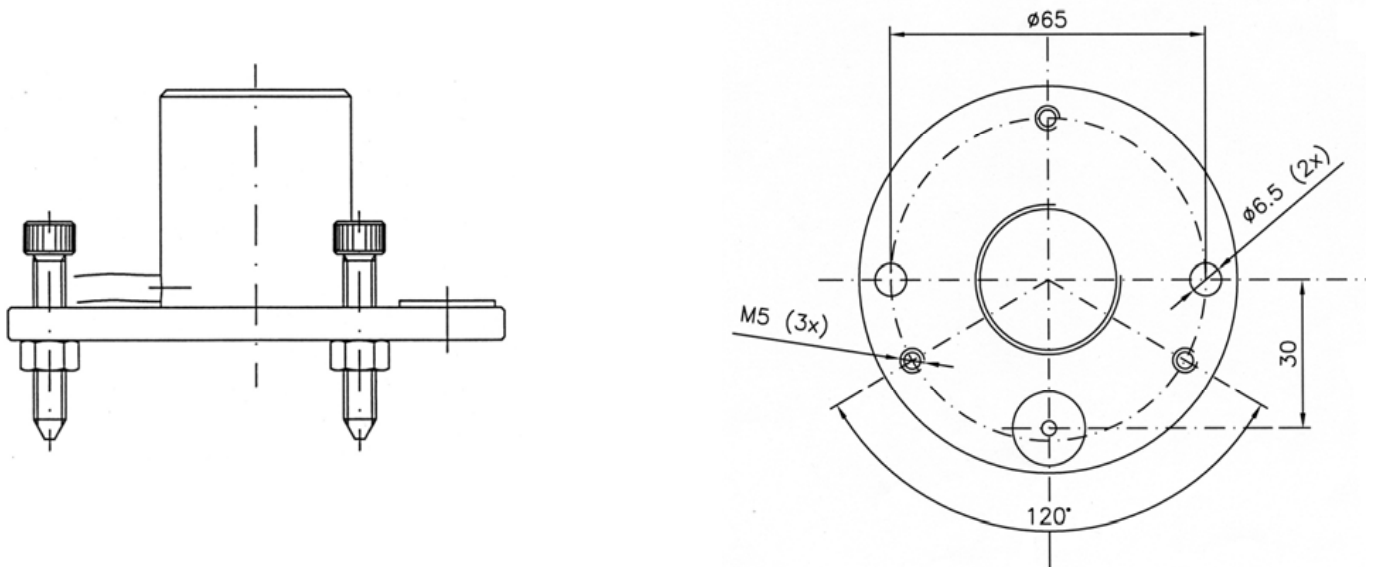

Figure 1 : LP PAR 04 BL

The instrument shall be supplied with constant voltage VDC in the range 5.5V-20V and has a voltage output of 0-2.5V, in the range 0-5000 [$(\mu\text{mol (phot)})/(\text{s m}^2)$].

Features

Directional sensor properties

The measurement of radiation across a surface is possible if the probe surface is a Lambert receiver. The difference between theoretical and measured response is shown in Figure 2.

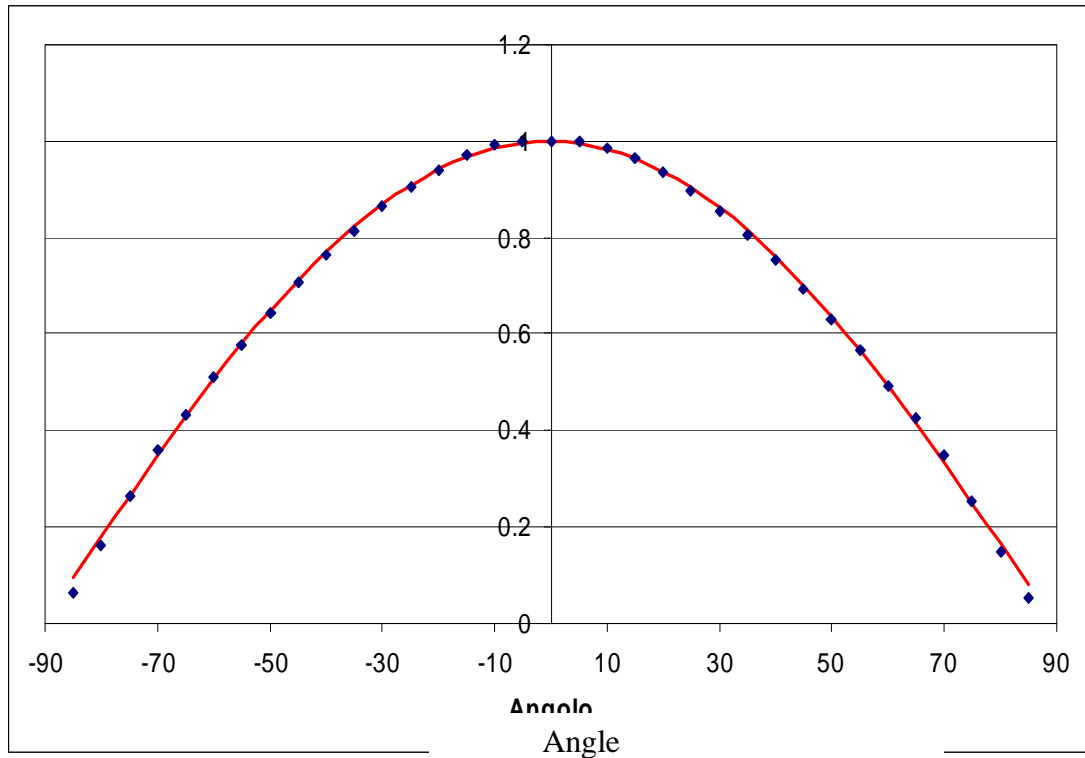

Figure 2

The excellent agreement between the measured response and cosine law allows to use the equipment at any solar elevation.

Positioning

LP PAR 04 BL can be used outdoor for long periods.

It is important to keep the diffuser cleaned. If necessary, the diffuser can be cleaned with water and a towel for cleaning optics.

N.B.: The probe is not designed to be submerged into water.

Electrical Connection:

The LP PAR 04 BL has an output cable in PTFE, UV resistant, has 4 wires + shield; the color code of the cable is shown in the following table:

Colour code LP PAR 04 BL

Color	Function
Black	Shield (⏏)
Red	(+) Vcc
Blue - Brown	(-) Vout e (-)Vcc
White	(+) Vout

Calibration and Measurements:

The probe calibration is performed by measuring the PAR flux emitted by a reference standard Halogen lamp.

The sensitivity is set:

$$0..2.5 \text{ V} = 0..5000 [(\mu\text{mol (phot)})/(\text{s m}^2)]$$

In order to obtain PAR flux the following procedure is to be applied:

-once you know the instrument output voltage (V_{out}) measured with the DMM, following formula must be applied:

$$PAR=2 \cdot V_{out}$$

where;

PAR: PAR flux $[(\mu\text{mol (phot)})/(\text{s m}^2)]$,

V_{out} : Output voltage [mV] measured by the voltmeter

Specifications:

Sensitivity:	0.5 mV/ $((\mu\text{mol (phot)})/(\text{s m}^2))$ [0-2.5V]
Measuring range:	0-5000 $[(\mu\text{mol (phot)})/(\text{s m}^2)]$
Spectral range:	400nm-700nm
Power supply:	5.5-20 VDC
Response time:	<0.5 s
Nonlinearity:	<1%
Stability :	< \pm 2% per year
Temperature drift:	< \pm 0.15%/ °C
Calibration uncertainty:	<3%
Response according to the cosine law:	\pm 3% angles between 0° - 75°
Working temperature:	-40°C + 65°C

Архангельск (8182)63-90-72	Ижевск (3412)26-03-58	Магнитогорск (3519)55-03-13	Пермь (342)205-81-47	Сургут (3462)77-98-35
Астана (7172)727-132	Иркутск (395)279-98-46	Москва (495)268-04-70	Ростов-на-Дону (863)308-18-15	Тверь (4822)63-31-35
Астрахань (8512)99-46-04	Казань (843)206-01-48	Мурманск (8152)59-64-93	Рязань (4912)46-61-64	Томск (3822)98-41-53
Барнаул (3852)73-04-60	Калининград (4012)72-03-81	Набережные Челны (8552)20-53-41	Самара (846)206-03-16	Тула (4872)74-02-29
Белгород (4722)40-23-64	Калуга (4842)92-23-67	Нижний Новгород (831)429-08-12	Санкт-Петербург (812)309-46-40	Тюмень (3452)66-21-18
Брянск (4832)59-03-52	Кемерово (3842)65-04-62	Новокузнецк (3843)20-46-81	Саратов (845)249-38-78	Ульяновск (8422)24-23-59
Владивосток (423)249-28-31	Киров (8332)68-02-04	Новосибирск (383)227-86-73	Севастополь (8692)22-31-93	Уфа (347)229-48-12
Волгоград (844)278-03-48	Краснодар (861)203-40-90	Омск (3812)21-46-40	Симферополь (3652)67-13-56	Хабаровск (4212)92-98-04
Вологда (8172)26-41-59	Красноярск (391)204-63-61	Орел (4862)44-53-42	Смоленск (4812)29-41-54	Челябинск (351)202-03-61
Воронеж (473)204-51-73	Курск (4712)77-13-04	Оренбург (3532)37-68-04	Сочи (862)225-72-31	Череповец (8202)49-02-64
Екатеринбург (343)384-55-89	Липецк (4742)52-20-81	Пенза (8412)22-31-16	Ставрополь (8652)20-65-13	Ярославль (4852)69-52-93
Иваново (4932)77-34-06	Киргизия (996)312-96-26-47	Казахстан (772)734-952-31	Таджикистан (992)427-82-92-69	