

Трансмиттеры DELTA OHM HD404T, HD404ST

Технические характеристики

Архангельск (8182)63-90-72
Астана (7172)727-132
Астрахань (8512)99-46-04
Барнаул (3852)73-04-60
Белгород (4722)40-23-64
Брянск (4832)59-03-52
Владивосток (423)249-28-31
Волгоград (844)278-03-48
Вологда (8172)26-41-59
Воронеж (473)204-51-73
Екатеринбург (343)384-55-89
Иваново (4932)77-34-06

Ижевск (3412)26-03-58
Иркутск (395)279-98-46
Казань (843)206-01-48
Калининград (4012)72-03-81
Калуга (4842)92-23-67
Кемерово (3842)65-04-62
Киров (8332)68-02-04
Краснодар (861)203-40-90
Красноярск (391)204-63-61
Курск (4712)77-13-04
Липецк (4742)52-20-81
Киргизия (996)312-96-26-47

Магнитогорск (3519)55-03-13
Москва (495)268-04-70
Мурманск (8152)59-64-93
Набережные Челны (8552)20-53-41
Нижний Новгород (831)429-08-12
Новокузнецк (3843)20-46-81
Новосибирск (383)227-86-73
Омск (3812)21-46-40
Орел (4862)44-53-42
Оренбург (3532)37-68-04
Пенза (8412)22-31-16
Казахстан (772)734-952-31

Пермь (342)205-81-47
Ростов-на-Дону (863)308-18-15
Рязань (4912)46-61-64
Самара (846)206-03-16
Санкт-Петербург (812)309-46-40
Саратов (845)249-38-78
Севастополь (8692)22-31-93
Симферополь (3652)67-13-56
Смоленск (4812)29-41-54
Сочи (862)225-72-31
Ставрополь (8652)20-65-13
Таджикистан (992)427-82-92-69

Сургут (3462)77-98-35
Тверь (4822)63-31-35
Томск (3822)98-41-53
Тула (4872)74-02-29
Тюмень (3452)66-21-18
Ульяновск (8422)24-23-59
Уфа (347)229-48-12
Хабаровск (4212)92-98-04
Челябинск (351)202-03-61
Череповец (8202)49-02-64
Ярославль (4852)69-52-93

Единый адрес для всех регионов: dmh@nt-rt.ru || www.deltaohm.nt-rt.ru

HD404T - HD404ST

- ▶ [GB] Very low pressure transmitters



Very low pressure transmitters



The series of HD404T transmitters is able to measure relative pressures with reference to the atmosphere or differential in the range:

- from 50 to 1000 Pa (from 0.2" H₂O to 4" H₂O) for the versions with analog output;
- 250 Pa / 1000 Pa / 100 mbar for the versions with RS485 Modbus-RTU output.

HD404T transmitters use a silicon "micro-machined" type sensor compensated in temperature that has an excellent linearity, repeatability and stability over time.

The output signal from the sensor is amplified and converted, depending on the model, into a standard current analog output (4-20 mA) and a voltage analog output (0-10 V), or into a digital RS485 Modbus-RTU output, which, then, can be transmitted over long distances with a high immunity to noise.

In the models with analog output it is possible to choose, via a dip switch, between two measurement ranges in order to select the optimal scale for each application.

Usually the low pressure transmitters are susceptible to the guidance by which they are mounted. In HD404T series there is available a special auto-zero circuit, which periodically equalize the differential pressure at the input sensor and corrects the offset; the transmitters, provided with this circuit, are insensitive to the mounting position. In addition, the circuit compensates auto-zero aging and the deviation of the zero of the sensor to temperature changes: virtually eliminates maintenance.

It's available the (L) "display" option, in which the pressure is visualized on a display with 4 digits in the selected measurement unit.

The (SR) "square root" is especially useful if the transmitter is connected to a Pitot or Darcy tube, as the output is directly proportional to the speed of airflow. The SR version with L option also allows to display, in addition to the pressure measured, the speed of airflow calculated. The SR version is configurable by the user by connecting the transmitter to a PC and sending serial commands via a standard communication software. It is possible to set the coefficient of the Pitot or Darcy tube used and the parameters for the calculation of the speed (airflow temperature, barometric pressure, differential static pressure in the duct). In the models with analog output it is possible to set the speed unit of measurement (m/s or ft/s) and the speed full scale for the analog output. In the models with RS485 Modbus-RTU output it is possible to read the measures in different units of measurement.

The transmitters are ready to use and are supplied calibrated by the manufacturer.

Typical applications for HD404T series are clean room monitoring, filters' control, flow measures (matched with the Pitot tube), the air conditioning control and the ventilation one.

Technical common features @ 20°C

Sensor	Piezoresistive
Measurement range	<ul style="list-style-type: none"> • Models with analog output: from 0...50 Pa (0...0.2" H₂O) to 0...1000 Pa (0...4" H₂O) relative and differential (see table 6) • Models with RS485 Modbus-RTU output: ±250 Pa, ±1000 Pa, ±100 mbar (see table) • For the SR models, the speed measurement ranges depend on the tube constant, the temperature and the pressure (see table 7 and figures 8 and 9)
Output signal	<ul style="list-style-type: none"> • Models with analog output: 0...10 Vdc (R_L > 10 kΩ) and 4...20 mA (R_L < 500 Ω @ 24 Vdc) • Models with digital output: RS485 Modbus-RTU
Accuracy	It depends on the model (see table 6)
Response time	<ul style="list-style-type: none"> • Models with analog output and dip-switch set to FAST: 0.125 s in pressure mode 1 s in speed mode • Models with analog output and dip-switch set to LOW: default 2 s, can be changed to 1 s or 4 s with a serial command • Models with RS485 Modbus-RTU output: default 2 s, can be changed to 0.125 s, 1 s or 4 s with a serial command
Over-pressure limit	50 kPa
Compatible media	Only air and non-aggressive gases
Power supply	<ul style="list-style-type: none"> • Models with analog output: 24 Vac ± 10% or 18...40 Vdc • Models with RS485 Modbus-RTU output: 12...30 Vdc
Absorption	<ul style="list-style-type: none"> • Models with analog output: < 1 W @ 24 Vdc • Models with RS485 Modbus-RTU output: < 100 mW @ 12 Vdc
Pressure fit	With Ø 5 mm flexible tube
Electrical connections	Terminal board with screws, max 1.5 mm ² , PG9 cable gland for input cable
Working conditions	-10...+60 °C (-5...+50 °C for models with auto-zero AZ), 0...95% RH
Storage temperature	-20...+70 °C
Case sizes	80 x 84 x 44 mm
Degree of protection	IP67



Fig. 1: transmitter with SR option connected to a Pitot tube

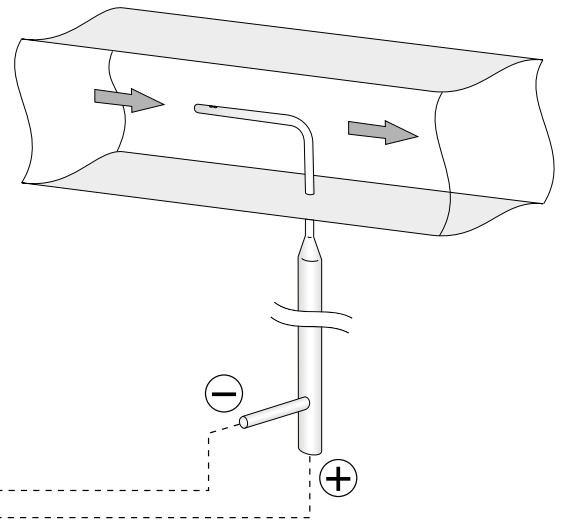

Installation

In all the models, the sensor and the electronic are contained in a sturdy plastic case with an IP67 protection degree. Opening the lid are available 3 mm diameter holes that let you set the base of the transmitter directly to a panel or a wall.

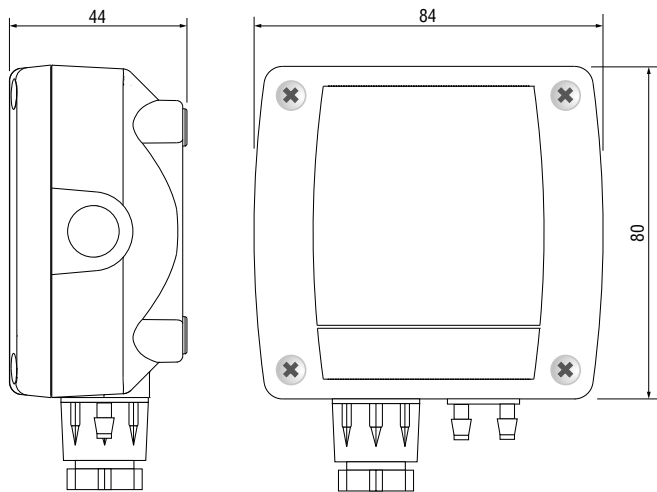

Fig. 2: dimensions (mm)

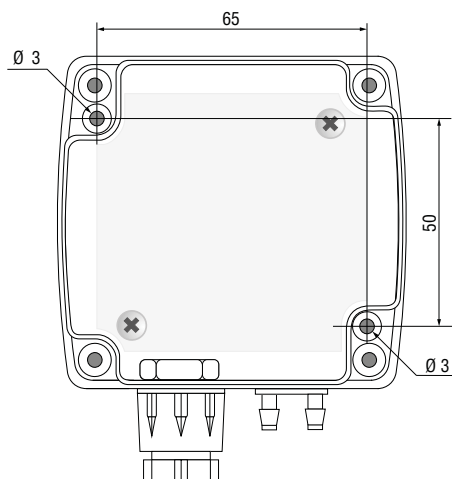

Fig. 3: fixing holes (dimensions in mm)

HD404T can be mounted in any position, but typically on a vertical wall with the pressure inlets facing downwards. The gap from zero due to the mounting position can be compensated by using CAL ZERO button. The procedure to follow for manual calibration of zero is the following one:

- Make sure that the transmitter is powered by at least 1 hour;
- Disconnect both tubes from the + and – pressure inlets;
- Press CAL ZERO button until the red LED starts to flash;
- When the red led turns off, the zero procedure is completed and you can reconnect the tubes to pressure fits.

We suggest you to perform the auto-zero procedure at least once a year under normal working conditions.

In models with auto-zero circuit (AZ option), this procedure is regularly performed every hour without disconnecting the hoses from pressure taps. During the reset, which takes about 4 seconds, the analogical outputs and the display will remain frozen at the measured value. Models with auto-zero have virtually no need for maintenance.

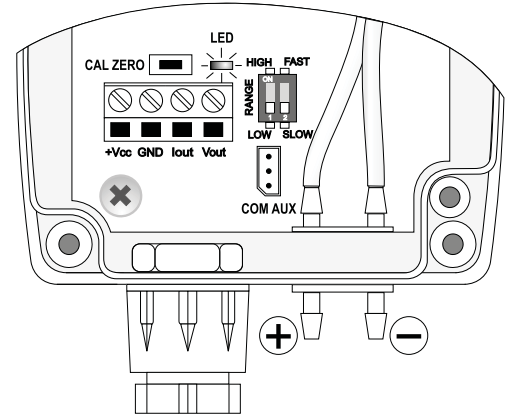

Models with analog output

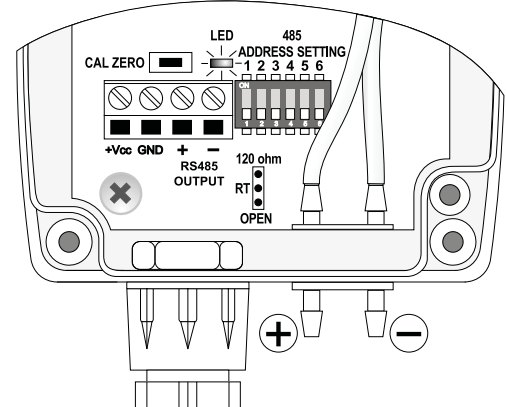

Models with RS485 output

Fig. 4: CAL ZERO button and configuration dip-switches

In the models with RS485 output and AZ option, the auto-zero interval can be set via the ZF serial command.

Electrical connections

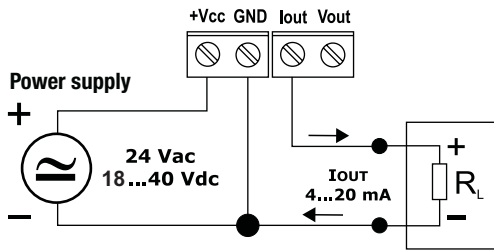

Fig. 5: current analog output

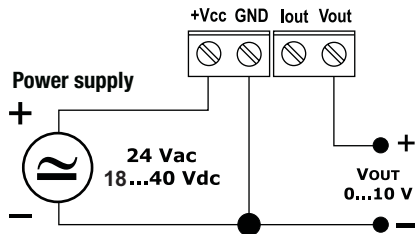

Fig. 6: voltage analog output

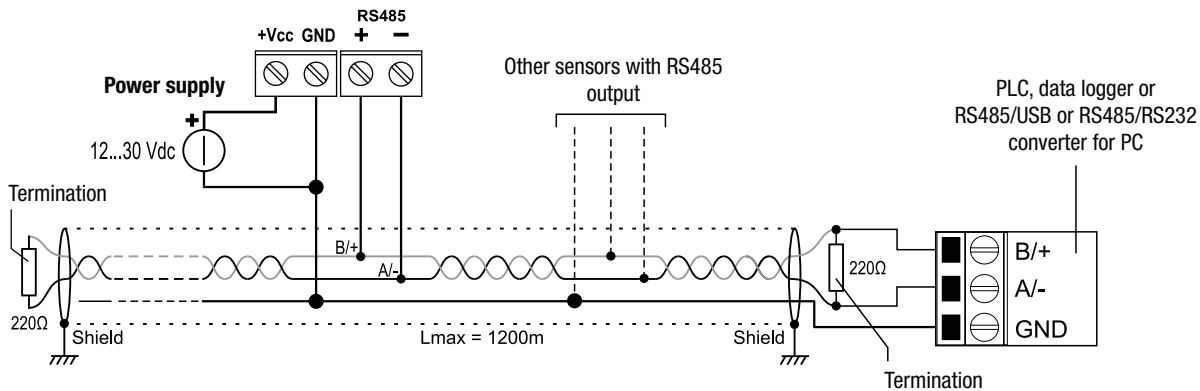

Fig. 7: RS485 connection

In the RS485 connection, the instruments are connected in a sequence through a shielded cable with twisted pair for signals and a third wire for the common. Line termination must be set at the two network ends.

The maximum number of devices that can be connected to the RS485 line (Bus) depends on the load characteristics of the devices to be connected. The RS485 standard requires that the total load does not exceed 32 unit loads. The load of an HD404ST... transmitter is equal to 1/4 of unit load. If the total load is greater than 32 unit loads, divide the network into segments and add a signal repeater between a segment and the successive one. Line termination should be applied at both ends of each segment.

The instrument has a built-in line termination that can be connected or removed through a short jumper placed next to the terminal block. If the instrument is the last or the first device of a network group, connect the termination placing the short jumper between the "RT" and "120 ohm" indications. If the instrument is not at the end of a network group, remove the termination placing the short jumper between the "RT" and "OPEN" indications.

The cable shield must be connected to both line ends. The cable should have the following features:

- Characteristic impedance: 120 ohm
- Capacity: less than 50pF/m
- Resistance: less than 100 ohm/km
- Gauge: 0,22 mm² (AWG24) at least

The cable maximum length depends on baud rate and cable characteristics. Typically, the maximum length is 1200 m. The data line must be kept separated from any power lines in order to prevent interferences on the transmitted signal.

Configuration

Setting the output range in the models with analog output

The RANGE dip-switch allows you to choose one of this output ranges: with LOW you choose the low range, with HIGH the extended range.

RS485 Modbus address (models HD404ST...)

Each transmitter of the network is univocally identified by an address between 1 and 247. **Transmitters having the same address shall not be present in the network.** The transmitter Modbus address is equal to the sum of the value set with the dip-switches 2...6 (value settable from 0 to 31) and the value set with the serial command WA (value settable from 1 to 216, default = 1, see the section "Setting the parameters in the models with RS485 Modbus RTU-output").

By setting a dip-switch to ON (upwards), the following values are added to the address:

	Dip-switch 2	Dip-switch 3	Dip-switch 4	Dip-switch 5	Dip-switch 6
ON	16	8	4	2	1
OFF	0	0	0	0	0

Example: if the dip-switches 2 and 4 are set to ON, and the dip-switches 3,5 and 6 are set to OFF, the value set with the dip-switches is 16+4=20. If the value set with the serial command WA is 1 (default value), the transmitter Modbus address is 20+1=21.

The dip-switches can be set even if the transmitter is powered, and the change is effective immediately.



Response time setting

In the models with analog output, the FAST / SLOW dip-switch lets you choose the response time of the transmitter: in FAST position the response time is 0.125 s in pressure measurement mode and about 1 s in speed measurement mode, while in SLOW position the response time is selectable to 1, 2 or 4 s by means of the S1, S2 or S4 serial commands respectively. SLOW position is recommended if there are conditions of turbulence or disruption of air flow.

In the models with RS485 output, the response time is selectable to 0.125 s, 1 s, 2 s or 4 s by means of the AVGO, AVG1, AVG2 or AVG4 serial commands respectively.

Setting the parameters in the models with analog output

The transmitters are preset by the factory. To change the settings, proceed as follows:

- Connect the transmitter COM AUX serial output to the PC RS232 (through the **RS27** cable) or USB (through the **CP27** cable) port. If the CP27 cable is used, install in the PC the related USB drivers.
- In the PC, run a serial communication software (e.g. Hyperterminal), set the baud rate to 115200 and the communication parameters to 8N2.
- To change the display configuration or the operating mode (commands O3E, O3D, O4E, O4D, O5E, O5D, O6E, O6D, O7E, O7D, O8E, O8D) it is necessary to send the **CAL START** command to enter the configuration mode. It is not necessary to send the CAL START command to change the parameters related to the speed measurement (tube coefficient, temperature, pressure, full scale for the analog output).
- Send the commands given in table 1 to set or read the configuration parameters of the transmitter (the commands that affect the speed or the flow have effect only in the versions with SR option).

TAB. 1: serial commands (models with analog output)

Command	Reply	Description
Sn	&n sec	Set the response time of index n for the analog outputs n=1 ⇒ 1 s n=2 ⇒ 2 s n=4 ⇒ 4 s
S?	n sec	Reads the response time set for the analog outputs
O3E	&	Shows alternately speed (or flow) and pressure on display
O3D	&	Disables the alternating display of speed (or flow) and pressure
O4E	&	Automatic change of speed resolution on display (0,1 ⇔ 0,01) depending on the measured value (see note 1)
O4D	&	Fixed centesimal speed resolution on display (see note 1)
O5E	&	Sets ft/s as speed unit of measurement on display <i>Note:</i> the symbol ft/s does not appear on display
O5D	&	Sets m/s as speed unit of measurement on display (default)
O6E	Model description	Enables "Debimo" sensor
O6D	Model description	Enables Pitot or Darcy sensor (default)
O7E	Model description	Enables flow mode
O7D	Model description	Enables speed mode (default)
O8E	Model description	Sets m ³ /min as flow unit of measurement
O8D	Model description	Sets L/s as flow unit of measurement
CK n.n...	&	Sets the Pitot or Darcy tube coefficient to the value n.n... The value must be between 0.6 and 1.2 (default = 1)
RK	n.nnnnnl	Reads the value of the Pitot or Darcy tube coefficient set in the transmitter
D nnnn	nnnn mmq	Sets and reads the duct section in mm ²
CD n.n	&	Sets the "Debimo" blades coefficient to the value n.n (default=0.8)
CB nnnn. nn...	&	Sets the barometric pressure to the value nnnn.nn... mbar The value must be between 500 and 1500 mbar (default = 1013.25 mbar)

Command	Reply	Description
RB	nnnn.nnnl	Reads the value of the barometric pressure in mbar set in the transmitter
CT n...	&	Sets the airflow temperature in tenths of °C (default = 160 ⇔ 16.0 °C) The value must be between -999 (⇒ -99.9 °C) and 2000 (⇒ 200.0 °C)
RT	n...l	Reads the value of the temperature, in tenths of °C, set in the transmitter
CP nnnn...	&	Sets the differential static pressure (see note 2) in mbar (default = 0)
RP	nnnn...l	Reads the value of the differential static pressure set in the transmitter
CS nnnn	&	In speed mode, sets the full scale speed, in hundredths of m/s, for the analog output (default = see table). The max settable value is 10000 (⇒ 100.00 m/s) In flow mode, sets the full scale flow in L/s or m ³ /min
RS	nn.nnl	In speed mode, reads the speed full scale value, in m/s, for the analog output In flow mode, reads the flow full scale value, in L/s or m ³ /min, for the analog output
SV	nn.nnl	In speed mode, prints the max measurable speed as a function of the transmitter full scale pressure and values set for the parameters. The value is in the speed unit of measurement set in the transmitter. In flow mode, prints the max measurable flow in L/s or m ³ /min.

Setting the parameters in the models with RS485 Modbus-RTU output

The transmitters are preset by the factory. To change the settings, proceed as follows:

- Connect the transmitter RS485 output to the PC RS232 (through a RS485/RS232 converter) or USB (through a RS485/USB converter, for example the **RS48** cable) port. If a RS485/USB converter is used, install in the PC the related USB drivers.
- To enable the configuration mode, set the **dip-switch 1** (the one closest to the terminal block) to **ON** (upwards), then power the transmitter.
Note: the dip-switch 1 can be changed from OFF to ON even when the instrument is powered; in this case it is however necessary, after setting the dip-switch to ON, to press briefly (less than 0.5 seconds) the CAL ZERO button to enable the configuration mode (the transmitter model information appears on display, if present). Alternatively, power cycle the transmitter.
- In the PC, run a serial communication software (e.g. Hyperterminal), set the baud rate to 57600 and the communication parameters to 8N1.
- Send the **CAL START** command (the command is required to change the configuration; to read the value of the parameters, the command is not required).
- Send the commands given in table 2 to set or read the configuration parameters of the transmitter (the commands that affect the speed or the flow have effect only in the versions with SR option).

TAB. 2: serial commands (models with RS485 Modbus-RTU output)

Command	Description
AVGn	Set the response time of index n for the measurement n=0 ⇒ 0.125 s n=1 ⇒ 1 s n=2 ⇒ 2 s n=4 ⇒ 4 s
AVG?	Reads the response time set for the measurement
DU0	Shows pressure in Pa on display
DUF	Shows flow in l/min on display (only in the versions with SR option)
DUV	Shows speed in m/s on display (only in the versions with SR option)
OPT3E	Shows alternately speed (or flow) and pressure on display
OPT3D	Disables the alternating display of speed (or flow) and pressure
OPT4E	Automatic change of speed resolution on display (0,1 ↔ 0,01) depending on the measured value (see note 1)
OPT4D	Fixed centesimal speed resolution on display (see note 1)
OPT6E	Enables "Debimo" sensor
OPT6D	Enables Pitot sensor (default)
WK n.n...	Sets the Pitot or Darcy tube coefficient to the value n.n... The value must be between 0.6 and 1.2 (default = 1)
RK	Reads the value of the Pitot or Darcy tube coefficient set in the transmitter
WD n.n...	Sets the "Debimo" sensor coefficient to the value n.n... The value must be between 0.6 and 1.2 (default = 1)
RD	Reads the value of the "Debimo" sensor coefficient set in the transmitter
WS nnnn	Sets the duct section in mm ²
RS	Reads the duct section in mm ²
WB nnnn. nn...	Sets the barometric pressure to the value nnnn.nn... hPa The value must be between 100 and 2000 hPa (default = 1013.25 hPa)
RB	Reads the value of the barometric pressure in hPa set in the transmitter
WT nn.n	Sets the airflow temperature in °C The value must be between -20.0 °C and +60.0 °C
RT	Reads the value of the temperature in °C set in the transmitter
WP nnnn...	Sets the differential static pressure (see note 2) in Pa (default = 0)
RP	Reads the value of the differential static pressure set in the transmitter
Auto-zero	
ZFn	Sets the auto-zero interval of index n (only in the versions with AZ option) n=0 ⇒ disabled n=1 ⇒ 5 min n=2 ⇒ 10 min n=3 ⇒ 20 min n=4 ⇒ 30 min n=5 ⇒ 60 min Default = 60 min
ZF?	Reads the auto-zero interval set (only in the versions with AZ option)
Modbus parameters	
WA n...n	Sets the Modbus base address to the value n...n The value must be between 1 and 216 (default = 1) Warning: the actual Modbus address of the transmitter is equal to the base address set with this command plus the value set with the dip-switches. Note: in the reply to the command, the previous actual address appears; the new address will appear in the replies to the next commands.
BAUD r...r	Sets the Modbus Baud Rate to the value r...r The acceptable values are 9600 and 19200 (default = 19200) If the command is sent without the parameter r...r, the current setting is obtained
PAR p	Sets the Modbus communication parameters of index p p=0 ⇒ 801 p=N ⇒ 8N2 p=E ⇒ 8E1 If the command is sent without the index p, the current setting is obtained (default = 8E1).

Note 1: The speed is calculated from the pressure measure through a quadratic relationship. For this reason, the speed resolution is lower for low pressure values measured, and the change of the speed measurement on the display appears rather discontinuous if the fixed centesimal resolution is used. If a more uniform speed change on display is desired, enable the automatic speed resolution change as a function of the measured value.

Note 2: The differential static pressure is equal to the difference between the absolute static pressure inside the duct and the barometric pressure. The differential static pressure is zero if the duct is open (in contact with the atmosphere), while it can be different from zero in case of closed ducts.

Nota 3: the replies of the transmitters with RS485 Modbus-RTU output always start with the address of the connected transmitter. For example, sending the RB command to a transmitter with Modbus address 1, the reply is "001: ATM pressure = 1013.250 hPa".

To exit the configuration mode after sending the CAL START command, send the CAL END command (the transmitter automatically exits the configuration mode after 5 minutes from the last command sent).

Flow measurement: the transmitter can be set in flow measurement mode (serial command 07E in the models with analog output, serial command DUF in the models with RS485 Modbus output). The flow is calculated from the speed measurement and the duct section set. The flow mode is available both with Pitot and "Debimo" sensors.

Modbus-RTU mode

to operate with the Modbus-RTU protocol be sure that the **dip-switch 1** (the one closest to the terminal block) is set to **OFF** (downwards). The dip-switch can be set to OFF even if the transmitter is powered, and the change is effective immediately.

The measured values can be read in Modbus-RTU mode by using the 04h function code (Read Input Registers). Table 3 lists the Modbus Input Registers available:

TAB. 3: MODBUS Input Registers

Register number	Register address	Datum	Format
4	3	Pressure in tenths of Pa (only HD404ST2...)	16-bit integer
5	4	Pressure in Pa (only HD404ST2... and HD404ST4...)	16-bit integer
6	5	Pressure in daPa (only HD404ST4... and HD404ST5-AZ...)	16-bit integer
7	6	Pressure in hPa (only HD404ST4 without AZ option and HD404ST5...)	16-bit integer
8	7	Pressure in kPa (only HD404ST5...)	16-bit integer
9	8	Pressure in hundredths of mmH ₂ O (only HD404ST2... and HD404ST4-AZ...)	16-bit integer
10	9	Pressure in tenths of mmH ₂ O (only HD404ST2... and HD404ST4...)	16-bit integer
11	10	Pressure in mmH ₂ O (only HD404ST4... and HD404ST5-AZ...)	16-bit integer
12	11	Pressure in thousandths of inchH ₂ O (only HD404ST2... and HD404ST4-AZ...)	16-bit integer
13	12	Pressure in hundredths of inchH ₂ O (only HD404ST4...)	16-bit integer
14	13	Pressure in tenths of inchH ₂ O (only HD404ST4 without AZ option and HD404ST5...)	16-bit integer
15	14	Pressure in inchH ₂ O (only HD404ST5...)	16-bit integer
16	15	Pressure in thousandths of mmHg (only HD404ST4-AZ...)	16-bit integer
17	16	Pressure in hundredths of mmHg (only HD404ST4...)	16-bit integer
18	17	Pressure in tenths of mmHg (only HD404ST4 without AZ option and HD404ST5-AZ...)	16-bit integer
19	18	Pressure in mmHg (only HD404ST5...)	16-bit integer
20	19	Pressure in thousandths of PSI (only HD404ST4 without AZ option)	16-bit integer
21	20	Pressure in hundredths of PSI (only HD404ST4 without AZ option and HD404ST5...)	16-bit integer
22	21	Speed in hundredths of m/s (only models with SR option)	16-bit integer
23	22	Speed in hundredths of ft/s (only models with SR option)	16-bit integer
24	23	Flow in l/s (only models with SR option)	16-bit integer
25	24	Flow in l/min (only models with SR option)	16-bit integer
26	25	Flow in m ³ /min (only models with SR option)	16-bit integer
27	26	Error register	16-bit integer

Reading a register not available for a particular model returns the value -32768 (0x8000).

If the pressure measurement is negative, the speed and flow registers return zero.

Error register

The bits of the error register signal, if set to 1, anomalies in the measurement. The bit 0 (the less significant one) indicates a measurement over-range of the transmitter. The bit 1 indicates whether the measurement is less than the minimum measurable (under-range). The bits 2 and 3 indicate sensor errors.

TAB. 4: MODBUS Holding Registers

Register number	Register address	Datum	Format
101	100	Modbus base address (from 1 to 216) Warning: the actual Modbus address of the transmitter is equal to the base address set in this register plus the value set with the dip-switches.	16-bit integer
102	101	Modbus Baud Rate Acceptable values: 3 (⇒ 9600) and 4 (⇒ 19200)	16-bit integer
103	102	Modbus communication parameters Acceptable values: 1 (⇒ 8N2), 2 (⇒ 8E1) and 4 (⇒ 801)	16-bit integer

The Modbus Holding Registers allow setting the same Modbus parameters that can be set via the serial commands WA, BAUD and PAR. Use the 06h (Write Single Register) and 03h (Read Holding Registers) function codes to write and read respectively the content of the registers.

To make the changes of the Holding Registers content active and permanent, write the hexadecimal value FF00 in the Coil Register number 3 (address 2) by using the 05h function code (Write Single Coil).

TAB. 5: MODBUS Coils

Register number	Register address	Datum
3	2	Activation and permanent storage of the Holding Registers content changes.

Display

Models with L option are provided with a 4-digit LCD display.

Pressure display resolution:

50 - 100 - 250 - 500 Pa	⇒ 0.5 Pa (0.1 in the model HD404ST2...)
1000 Pa	⇒ 1 Pa
100 mbar	⇒ 0.1 mbar
5 - 10 - 25 - 50 mmH ₂ O	⇒ 0.05 mmH ₂ O
100 mmH ₂ O	⇒ 0.1 mmH ₂ O
0.2 - 0.4 - 1 - 2 - 4 inchH ₂ O	⇒ 0.002 inchH ₂ O

Speed display resolution in the SR models: for all the ranges, the speed resolution can be centesimal fixed or with automatic change from decimal to centesimal as a function of the measured value. The selection between the two options is made via the serial commands O4E and O4D in the models with analog output, and via the serial commands OPT4E and OPT4D in the models with RS485 Modbus-RTU output.

Error reporting:

Undr	⇒ it appears if the measured value is smaller than the minimum value that can be measured.
Over	⇒ it appears if the measured value exceeds the maximum value that can be measured.
CAL Error	⇒ it appears when the zero calibration is finished if the maximum offset value that can be corrected is exceeded.

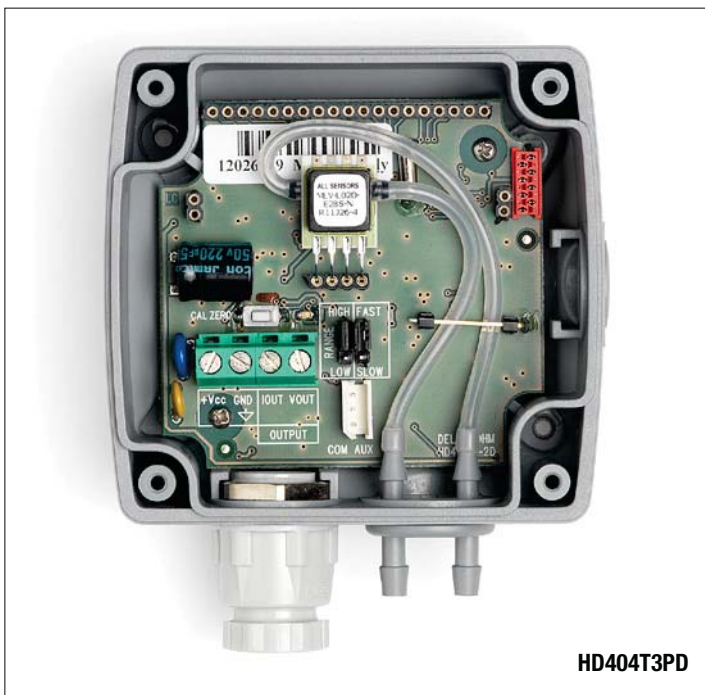

Tab. 6: Summary table of models and accuracy

MODEL	RANGE		ACCURACY %F.S. RANGE HIGH (0...+50 °C)	LONG TERM STABILITY (1 YEAR)	
	LOW	HIGH		AZ	NO AZ
	Pa				
HD404T1PG-AZ(-L-SR)	0...50 Pa	0...100 Pa	±3%	≤±1Pa	
HD404T2PG-AZ(-L-SR)	0...100 Pa	0...250 Pa	±1.5%	≤±1Pa	
HD404T3PG(-AZ-L-SR)	0...250 Pa	0...500 Pa	±1%	≤±1Pa	≤±8Pa
HD404T4PG(-AZ-L-SR)	0...500 Pa	0...1000 Pa	±1%	≤±1Pa	≤±8Pa
HD404T1PD-AZ(-L)	-50...+50 Pa	-100...+100 Pa	±1.5%	≤±1Pa	
HD404T2PD-AZ(-L)	-100...+100 Pa	-250...+250 Pa	±1%	≤±1Pa	
HD404T3PD(-AZ-L)	-250...+250 Pa	-500...+500 Pa	±1%	≤±1Pa	≤±8Pa
HD404T4PD(-AZ-L)	-500...+500 Pa	-1000...+1000 Pa	±1%	≤±1Pa	≤±8Pa
	mmH ₂ O				
HD404T1MG-AZ(-L-SR)	0...5 mmH ₂ O	0...10 mmH ₂ O	±3%	≤±0.1mmH ₂ O	
HD404T2MG-AZ(-L-SR)	0...10 mmH ₂ O	0...25 mmH ₂ O	±1.5%	≤±0.1mmH ₂ O	
HD404T3MG(-AZ-L-SR)	0...25 mmH ₂ O	0...50 mmH ₂ O	±1%	≤±0.1mmH ₂ O	≤±0.8mmH ₂ O
HD404T4MG(-AZ-L-SR)	0...50 mmH ₂ O	0...100 mmH ₂ O	±1%	≤±0.1mmH ₂ O	≤±0.8mmH ₂ O
HD404T1MD-AZ(-L)	-5...+5 mmH ₂ O	-10...+10 mmH ₂ O	±1.5%	≤±0.1mmH ₂ O	
HD404T2MD-AZ(-L)	-10...+10 mmH ₂ O	-25...+25 mmH ₂ O	±1%	≤±0.1mmH ₂ O	
HD404T3MD(-AZ-L)	-25...+25 mmH ₂ O	-50...+50 mmH ₂ O	±1%	≤±0.1mmH ₂ O	≤±0.8mmH ₂ O
HD404T4MD(-AZ-L)	-50...+50 mmH ₂ O	-100...+100 mmH ₂ O	±1%	≤±0.1mmH ₂ O	≤±0.8mmH ₂ O
	inchH ₂ O				
HD404T1IG-AZ(-L-SR)	0...0.2 inchH ₂ O	0...0.4 inchH ₂ O	±3%	≤±0.004inchH ₂ O	
HD404T2IG-AZ(-L-SR)	0...0.4 inchH ₂ O	0...1 inchH ₂ O	±1.5%	≤±0.004inchH ₂ O	
HD404T3IG(-AZ-L-SR)	0...1 inchH ₂ O	0...2 inchH ₂ O	±1%	≤±0.004inchH ₂ O	≤±0.04inchH ₂ O
HD404T4IG(-AZ-L-SR)	0...2 inchH ₂ O	0...4 inchH ₂ O	±1%	≤±0.004inchH ₂ O	≤±0.04inchH ₂ O
HD404T1ID-AZ(-L)	-0.2...0.2 inchH ₂ O	-0.4...0.4 inchH ₂ O	±1.5%	≤±0.004inchH ₂ O	
HD404T2ID-AZ(-L)	-0.4...0.4 inchH ₂ O	-1...+1 inchH ₂ O	±1%	≤±0.004inchH ₂ O	
HD404T3ID(-AZ-L)	-1...+1 inchH ₂ O	-2...+2 inchH ₂ O	±1%	≤±0.004inchH ₂ O	≤±0.04inchH ₂ O
HD404T4ID(-AZ-L)	-2...+2 inchH ₂ O	-4...+4 inchH ₂ O	±1%	≤±0.004inchH ₂ O	≤±0.04inchH ₂ O
	MODELS WITH RS485 MODBUS-RTU OUTPUT				
HD404ST2-AZ(-L-SR)	-250...+250 Pa		±1.5%	≤±1Pa	
HD404ST4(-AZ-L-SR)	-1000...+1000 Pa		±1%	≤±1Pa	≤±8Pa
HD404ST5(-AZ-L-SR)	-100...+100 mbar		±1%	≤±1Pa	≤±8Pa

Speed full scale in the SR models

In the SR models, the maximum speed measurable depends on the coefficient of the tube used, the temperature, the barometric pressure and the differential static pressure set in the transmitter. In the models with analog output, the serial command SV allows reading the maximum speed measurable as a function of the parameters setting. Table 7 shows the maximum speed measurable by the various models with the values of the parameters preset by the factory: tube coefficient **K = 1.0**, temperature **T = 16.0 °C**, barometric pressure **Patm = 1013.25 mbar**, differential static pressure **Ps = 0**.

TAB. 7: max speed measurable

MODEL	MAX SPEED MEASURABLE (@ K = 1, T = 16°C, Patm = 1013.25 mbar, Ps = 0)		DEFAULT FULL SCALE FOR THE ANALOG OUTPUT (changeable with the CS command)
	LOW	HIGH	
HD404T1PG-AZ(-L)-SR	9.06 m/s	12.82 m/s	10 m/s
HD404T2PG-AZ(-L)-SR	12.82 m/s	20.27 m/s	20 m/s
HD404T3PG(-AZ-L)-SR	20.27 m/s	28.67 m/s	25 m/s
HD404T4PG(-AZ-L)-SR	28.67 m/s	40.55 m/s	40 m/s
HD404T1MG-AZ(-L)-SR	8.98 m/s	12.70 m/s	10 m/s
HD404T2MG-AZ(-L)-SR	12.70 m/s	20.08 m/s	20 m/s
HD404T3MG(-AZ-L)-SR	20.08 m/s	28.39 m/s	25 m/s
HD404T4MG(-AZ-L)-SR	28.39 m/s	40.16 m/s	40 m/s
HD404T1IG-AZ(-L)-SR	9.05 m/s	12.80 m/s	10 m/s
HD404T2IG-AZ(-L)-SR	12.80 m/s	20.24 m/s	20 m/s
HD404T3IG(-AZ-L)-SR	20.24 m/s	28.62 m/s	25 m/s
HD404T4IG(-AZ-L)-SR	28.62 m/s	40.48 m/s	40 m/s

The following graphs show the change of the maximum measurable speed value (normalized to 1 for T=16.0 °C and Patm=1013.25 mbar) with the change of the temperature and barometric pressure.

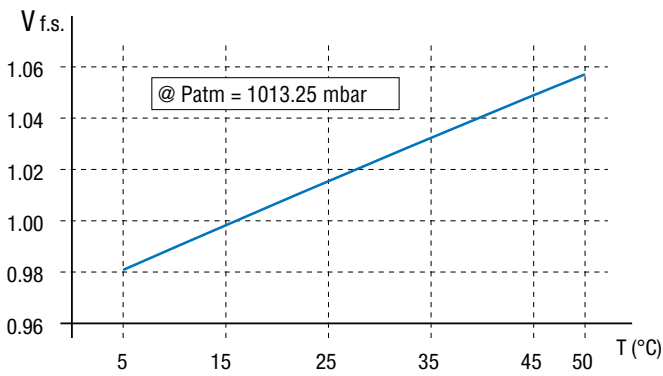

Fig. 8: change of the full scale speed with the temperature at constant barometric pressure

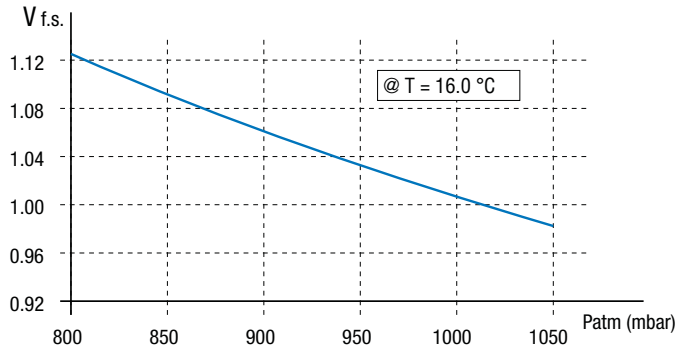

Fig. 9: change of the full scale speed with the barometric pressure at constant temperature

In the SR models, the serial command "CS nnnn" allows to associate to the full scale of the analog output a speed value chosen by the user, even different from the maximum value actually measurable by the transmitter.

Ordering codes

Models with analog output:

HD404T **1P** - **G** - **AZ** - **L** - **SR**

SR = speed measurement option

L = with LCD display

AZ = with auto-zero circuit

D = differential pressure -f.s...+f.s.

G = relative pressure with reference to the atmosphere 0...+f.s.

Nominal full scale (f.s.):

1P = 100Pa, **2P** = 250Pa, **3P** = 500Pa, **4P** = 1000Pa
1M = 10mmH₂O, **2M** = 25mmH₂O, **3M** = 50mmH₂O, **4M** = 100mmH₂O
1I = 0.4inchH₂O, **2I** = 0.8inchH₂O, **3I** = 2inchH₂O, **4I** = 4inchH₂O

Models with RS485 Modbus-RTU output:

HD404ST **2** - **AZ** - **L** - **SR**

SR = speed measurement option

L = with LCD display

AZ = with auto-zero circuit

Note: HD404ST2 has always the auto-zero

Full scale (f.s.):

2 = -250 ... +250 Pa
4 = -1000 ... +1000 Pa
5 = -100 ... +100 mbar



ACCESSORIES

Supplied:

- N°1 piece of $\varnothing 3.2/\varnothing 6.4$ silicone tube 2 m long
- N°2 HD434T.5 plastic fittings

Under request:

AP3719 Flow offtake for square or cylindrical channel. Two pieces of $\varnothing 3.2/\varnothing 6.4$ tube 1 m long.

AP3721 Flow offtake for plastic material cylindrical channel. Two pieces of $\varnothing 3.2/\varnothing 6.4$ tube 1 m long.

RS27 RS232 null-modem serial connection cable with 9-pole SubD connector for the PC and 3-pole connector for the COM AUX port of the instrument.

CP27 Serial connection cable with USB connector for the PC and 3-pole connector for the COM AUX port of the instrument. The cable has a built-in USB/RS232 converter and connects the transmitter directly to the USB port of the PC.

RS48 Cable for RS485 connection with built-in USB/RS485 converter. The cable has USB connector for PC and 3 separate wires for the instruments.

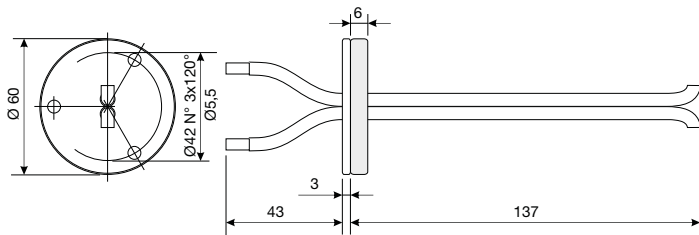

Fig. 10: AP3719 duct probe

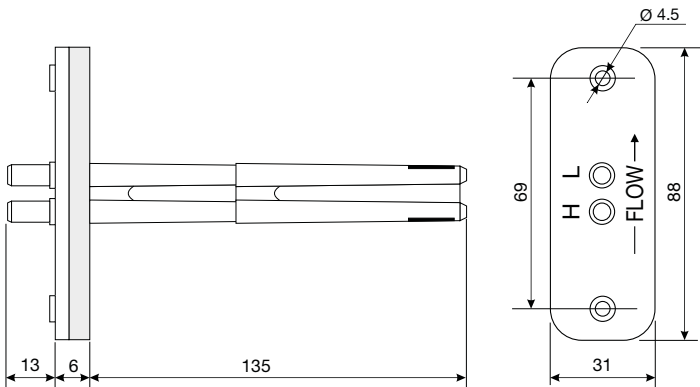
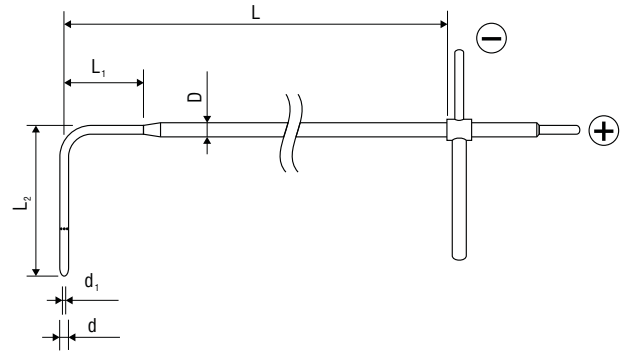

Fig. 11: AP3721 duct probe

PITOT TUBES

Stainless steel Pitot tubes for air speed measurement, supplied with silicone tube $\varnothing 6$ mm external, $\varnothing 4$ mm internal, length 2m.



	d mm	d ₁ mm	D mm	L mm	L ₁ mm	L ₂ mm	Temp. °C	Material
T1-300	3	1	6	300	30	72	0...600°C	AISI 316
T2-400	5	2	8	400	45	120		
T2-600	5	2	8	600	45	120		
T3-500	8	3.2	8	500	---	192		
T3-800	8	3.2	8	800	---	192		
T4-500	10	4.0	10	500	---	240		
T4-800	10	4.0	10	800	---	240		
T4-1000	10	4.0	10	1000	---	240		

Examples of connection with HD9022 indicator regulator

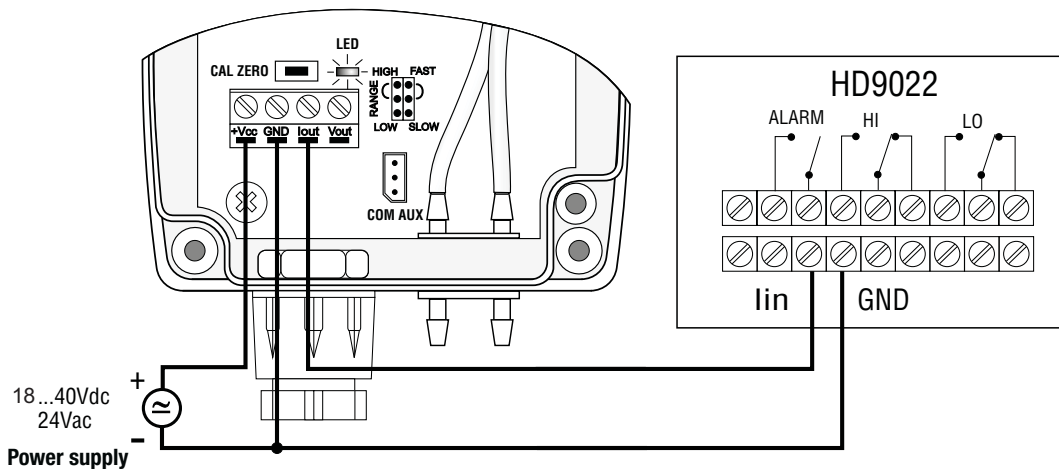

Fig. 12: 4...20 mA current output

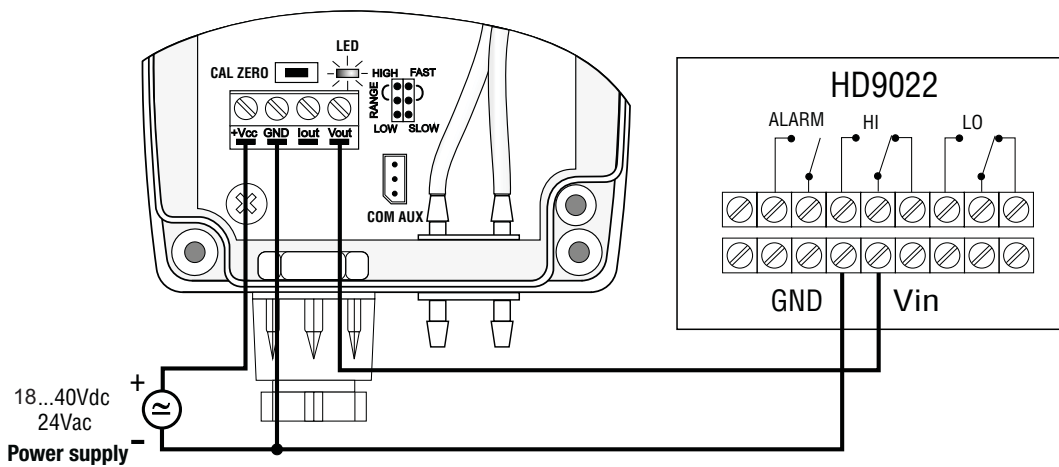

Fig. 13: 0...10 Vdc voltage output

Архангельск (8182)63-90-72
 Астана (7172)727-132
 Астрахань (8512)99-46-04
 Барнаул (3852)73-04-60
 Белгород (4722)40-23-64
 Брянск (4832)59-03-52
 Владивосток (423)249-28-31
 Волгоград (844)278-03-48
 Вологда (8172)26-41-59
 Воронеж (473)204-51-73
 Екатеринбург (343)384-55-89
 Иваново (4932)77-34-06

Ижевск (3412)26-03-58
 Иркутск (395)279-98-46
 Казань (843)206-01-48
 Калининград (4012)72-03-81
 Калуга (4842)92-23-67
 Кемерово (3842)65-04-62
 Киров (8332)68-02-04
 Краснодар (861)203-40-90
 Красноярск (391)204-63-61
 Курск (4712)77-13-04
 Липецк (4742)52-20-81
 Киргизия (996)312-96-26-47

Магнитогорск (3519)55-03-13
 Москва (495)268-04-70
 Мурманск (8152)59-64-93
 Набережные Челны (8552)20-53-41
 Нижний Новгород (831)429-08-12
 Новокузнецк (3843)20-46-81
 Новосибирск (383)227-86-73
 Омск (3812)21-46-40
 Орел (4862)44-53-42
 Оренбург (3532)37-68-04
 Пенза (8412)22-31-16
 Казахстан (772)734-952-31

Пермь (342)205-81-47
 Ростов-на-Дону (863)308-18-15
 Рязань (4912)46-61-64
 Самара (846)206-03-16
 Санкт-Петербург (812)309-46-40
 Саратов (845)249-38-78
 Севастополь (8692)22-31-93
 Симферополь (3652)67-13-56
 Смоленск (4812)29-41-54
 Сочи (862)225-72-31
 Ставрополь (8652)20-65-13
 Таджикистан (992)427-82-92-69

Сургут (3462)77-98-35
 Тверь (4822)63-31-35
 Томск (3822)98-41-53
 Тула (4872)74-02-29
 Тюмень (3452)66-21-18
 Ульяновск (8422)24-23-59
 Уфа (347)229-48-12
 Хабаровск (4212)92-98-04
 Челябинск (351)202-03-61
 Череповец (8202)49-02-64
 Ярославль (4852)69-52-93