

Калибраторы акустические DELTA OHM HD2020

Технические характеристики

Архангельск (8182)63-90-72
Астана (7172)727-132
Астрахань (8512)99-46-04
Барнаул (3852)73-04-60
Белгород (4722)40-23-64
Брянск (4832)59-03-52
Владивосток (423)249-28-31
Волгоград (844)278-03-48
Вологда (8172)26-41-59
Воронеж (473)204-51-73
Екатеринбург (343)384-55-89
Иваново (4932)77-34-06

Ижевск (3412)26-03-58
Иркутск (395)279-98-46
Казань (843)206-01-48
Калининград (4012)72-03-81
Калуга (4842)92-23-67
Кемерово (3842)65-04-62
Киров (8332)68-02-04
Краснодар (861)203-40-90
Красноярск (391)204-63-61
Курск (4712)77-13-04
Липецк (4742)52-20-81
Киргизия (996)312-96-26-47

Магнитогорск (3519)55-03-13
Москва (495)268-04-70
Мурманск (8152)59-64-93
Набережные Челны (8552)20-53-41
Нижний Новгород (831)429-08-12
Новокузнецк (3843)20-46-81
Новосибирск (383)227-86-73
Омск (3812)21-46-40
Орел (4862)44-53-42
Оренбург (3532)37-68-04
Пенза (8412)22-31-16
Казахстан (772)734-952-31

Пермь (342)205-81-47
Ростов-на-Дону (863)308-18-15
Рязань (4912)46-61-64
Самара (846)206-03-16
Санкт-Петербург (812)309-46-40
Саратов (845)249-38-78
Севастополь (8692)22-31-93
Симферополь (3652)67-13-56
Смоленск (4812)29-41-54
Сочи (862)225-72-31
Ставрополь (8652)20-65-13
Таджикистан (992)427-82-92-69

Сургут (3462)77-98-35
Тверь (4822)63-31-35
Томск (3822)98-41-53
Тула (4872)74-02-29
Тюмень (3452)66-21-18
Ульяновск (8422)24-23-59
Уфа (347)229-48-12
Хабаровск (4212)92-98-04
Челябинск (351)202-03-61
Череповец (8202)49-02-64
Ярославль (4852)69-52-93

Единый адрес для всех регионов: dmh@nt-rt.ru || www.deltaohm.nt-rt.ru

HD2020



HD2020 ACOUSTIC CALIBRATOR

The HD 2020 sound level calibrator is a portable, battery operated sound source, suitable for sound level meters (portable and laboratory) and acoustic stations. It allows calibrating ½" microphones with mechanical dimensions compliant with IEC 61094-1 ("Measurement microphones. Part 1: Specifications for laboratory standard microphones") and IEC 61094-4 ("Measurement microphones. Part 4: Specifications for working standard microphones"). The calibration pressure levels of 94dB and 114dB can be selected by the keypad. The 1000 Hz frequency cannot be changed.

If the microphone is absent or not inserted correctly into the calibrator cavity, the sound level will blink on the display.

To conserve battery life, the instrument is provided with an automatic power off function: if you leave the instrument on with open cavity, it switches off automatically after 30 seconds. If the cavity is closed and the microphone is inserted, the instrument switches off 5 minutes after turning on, provided that you don't press any key.

The calibrator display shows calibration pressure level, battery life, current date and time.



The clock/calendar allows you to set the number of years and months of validity of the calibration from the date of adjusting: at the expiration time, an appropriate symbol flashes on the display.

ACOUSTIC CALIBRATOR

1. **ON-OFF** key: turns on and off the instrument. When you turn the instrument on, the display will switch on about three seconds later.
2. **SETUP** key: allows you to enter and scroll menu. To exit, press it repeatedly until you go back to the standard screen.
3. **Display**. When you turn the instrument on, it shows all segments on, and then the sound pressure level (94 or 114dB) will appear in standard view.
4. Calibrator cavity for conventional ½ inch microphones.
5. **▼** key: in standard mode, it selects 94dB and 114dB pressure levels alternately. In menu mode, it decreases the current value.
6. **▲** key: in standard mode, it selects 94dB and 114dB pressure levels alternately. In menu mode, it increases the current value.
7. Battery lid.

Advantages of the HD 2020 calibrator are:

- The 1000Hz frequency allows calibrating sound level meters with any weighting (LIN, A, B, ...), without applying any correction factor.
- The calibration sound pressure level is independent of atmospheric pressure: you don't need to adjust the value according to static pressure over a wide range of values.
- The HD 2020 calibrator can be conveniently used both in laboratory and in the field. The 114 dB sound level allows performing calibrations even in high background noise environments.
- Its simplicity of use allows the use even by unskilled personnel.
- The presence of the LCD helps you through the steps of setting the calibrator, signal the end of the span and allows you to check the status of the battery.

DESCRIPTION KEYBOARD AND DISPLAY

The keyboard instrument consists of 4 buttons.

The following describes in detail the functions performed by each.



ON-OFF key

Press the ON/OFF key to turn the instrument on and off.

When instrument is on, all display segments are shown for a few seconds,

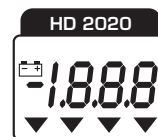

...an auto-test including the level of battery charge starts and brings the instrument to the standard working condition.

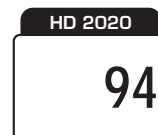

Note: between the instant when you press the ON / OFF button and switching the display pass about three seconds: this time it is necessary to perform the initial self-test.

Auto-off feature

The instrument has the auto-off feature (Auto-Power Off) that turns the meter off after 5 minutes if, in this interval, the microphone is inserted into the cavity of the calibrator and press any button.

If the cavity is open, indicating the noise level in the display: in these conditions the instrument will turn off automatically after 30 seconds

The Auto-off feature cannot be excluded.



SETUP key

The SETUP key allows entering and viewing the menu. To exit, press the SETUP key until you go back to the standard screen, or keep it pressed for more than 2 seconds.

The menu shows:

- Current date and time in the format year, month, day, hour, minute, second.
- Current date and time in the format year, month, day of the last calibration.
- The interval between the calibration date and the expiry date in years and months.

The user can set each of these items by selecting the SETUP button and modifying it with the arrow keys ▲ ▼. To confirm the setting, press the SETUP.

From the standard display, press SETUP to see the current year:



Use the arrows to increase / decrease the value. With the SETUP button is confirmed and changes to current month:



Use the arrows to increase / decrease the value. With the SETUP button is confirmed and passed to the current day:



Use the arrows to increase / decrease the value. With the SETUP button is confirmed and the current time passes.



Use the arrows to increase / decrease the value. With the SETUP button is confirmed and passed to the current minutes.



Use the arrows to increase / decrease the value. With the SETUP button is confirmed and passed to the second current.



Each time you press the arrow keys, the seconds value to zero. With the SETUP button you confirm and move to the menu section on the calibration with the lighting of the first triangle to the left and display of calibration (the parameter is not user editable).



With the SETUP button switches per month span (the parameter is not user editable).



With the SETUP button switches per day span (the parameter is not user editable).



With the SETUP button switch setting the date of calibration with the lighting of the second triangle to the left and display the number of years of calibration. You can type the number of years and months between the date of calibration, entered by the laboratory conducting the formal point and the expiry date.

After the interval set, the triangle is flashing to indicate that it is necessary to re-start point of the calibrator.

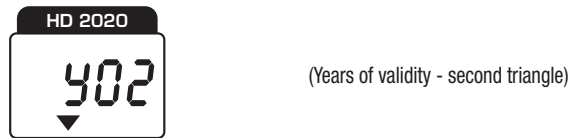

Use the arrows to increase / decrease the value. With the SETUP button you confirm and pass the number of months of validity.



Use the arrows to increase / decrease the value. With the SETUP button you confirm and back to the default mode of operation.



Under standard conditions, select either the sound pressure levels of 94dB and 114dB. In the menu increases the current value.



Under standard conditions, select either the sound pressure levels of 94dB and 114dB. In the menu decrements the current value.

CALIBRATION PROCEDURE

The HD 2020 can calibrate standard 1/2" microphones compliant with IEC 61094-1 and IEC61094-2. To calibrate the microphone, insert it deep into the cavity. The O-ring will offer some resistance.

The calibration can be effected by holding the HD2020 upright as well as by leaning the instruments on a worktable.

While measuring, you should move neither the microphone nor the calibrator; make sure that the worktable doesn't transmit vibrations.

A small misalignment of the microphone and calibrator axes is allowed.

• Before beginning to calibrate, you should make sure that the ambient noise level doesn't affect the calibration. After inserting the microphone into the cavity, with the sound level meter and the calibrator off, switch on the sound level meter and detect the unweighted ambient sound pressure level. If the measured level is below 78 dB, you can use both calibration sound levels (94 dB and 114 dB); if the level is between 78 dB and 98 dB you can use the 114 dB level only, while a sound level above 98 dB means that calibration is not possible.

- Press the ON/OFF key to switch the instrument on.
- Use the arrow keys to select the sound level: 94 dB or 114 dB.
- If the value displayed on the display stops flashing within a few seconds, this indicates improper placement of the microphone.
- Proceed with the calibration of sound level meter, following the procedure indicated on the instrument manual.
- Apply the correction to the pressure level generated in the type of microphone (see the following chapter).
- At the end, turn the sound level meter and calibrator off and remove the microphone from the cavity.

With the HD 2020 calibrator can calibrate any type of SLM is provided with a microphone or laboratory sample of work from 1/2" in conformity with the standards described in IEC 61094-01 and IEC 61094-4.

Corrections for the type of microphone

The HD2020 calibrator generates a sound pressure level equal to 94 dB (or 114 dB) reported in 20µPa. The normal working microphones 1/2", used on sound level meters are engineered to have a flat frequency response in terms of free field or diffuse field is respectively in a field of progressive plane waves with propagation direction coincides with the axis of microphone and in a field of sound waves from all directions. These propagation conditions are different from those experienced in the cavity of the sound calibrator. Free field reflections caused by the presence of the microphone alter the sound level by increasing the effective sensitivity of the capsule at high frequencies. The microphones are optimized for free-field measurements exploit this phenomenon to obtain a flat frequency response up to very high frequencies. In these microphones increase in noise level at 1 kHz is approximately 0.05 dB ÷ 0.20 dB. When you calibrate a microphone for free field should therefore reflect this difference in sound level meter by setting a noise level less than 0.1 dB and 0.2 dB compared to the nominal calibrator. The microphones are optimized for diffuse field measurements do not need instead of corrections when calibrated cavity closed at 1 kHz.

REPORTING FOR LOW BATTERY AND BATTERY REPLACEMENT

The calibrator HD 2020 is equipped with two batteries: a user-replaceable 9V alkaline battery and lithium. This serves to keep the clock and calendar function even if the external battery: its replacement should be done at an authorized by Delta Ohm.

The charge level of the 9V battery is continuously monitored:

- If the battery is fully charged, its symbol is off;
- If the battery is partially charged, its symbol blinks: please replace the battery as soon as possible;
- If the charge is insufficient to ensure normal operation of the instrument, the symbol remains constantly lit. When the battery is discharged, the calibrator is turned off within approximately 10 seconds.

To replace the 9V battery, turn off the power and open the door at the bottom of the instrument. Replace the battery. Close the door. The date, time interval expires calibration will be saved if the battery is fully charged. The average duration of the battery depends on the presence or absence of the external, if the external battery is present; the average life of battery is approximately 5 years.

Warning on use of batteries

- If the battery is low, replace it as soon as possible.
- Make sure that there is no loss of liquid.
- Use good quality sealed batteries (alkaline if possible).

CONSTRUCTION AND OPERATION

Mechanical construction

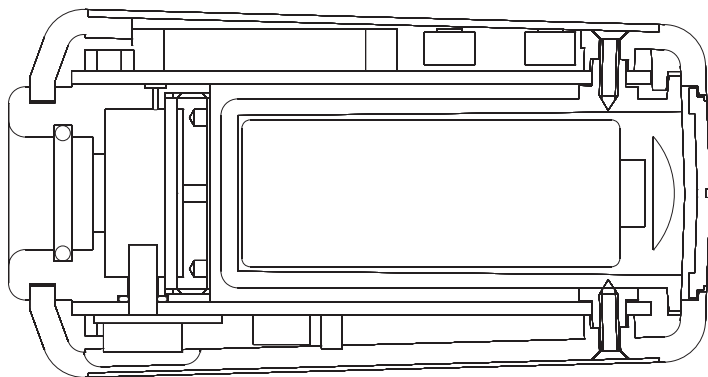

Fig. 3 Mechanical construction of the calibrator (section).

In Fig 3 is the schematic structure of the calibrator HD 2020 (in section). On the right side of the container is the battery compartment. Above and below the battery compartment are printed circuit boards and electronics. The upper one is reserved for the display and keyboard. At left is the electro-acoustic transduction system consists of a large volume cavity with piezoceramic generator and sensor feedback. The system emits a signal through the microphone located 1/2". A capillary hole outward balances the static pressure chamber protects the microphones from excessive pressure caused by the advertiser.

Electronic control

In Fig 4 shows the block diagram of the calibrator.

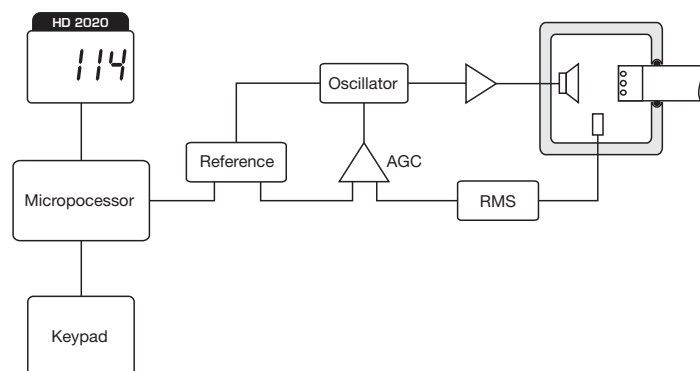

Fig 4 Block diagram of electronics.

The main part of electronics is an oscillator with high stability and low distortion plus an RMS converter, the automatic gain control (AGC), the driver for the ceramic resonator and electronics packaging of the signal provided by sensor feedback. The RMS level of the signal provided by the sensor is compared with the reference level set at the factory, the difference corrected by the automatic gain control, the amplitude of the signal generated by the oscillator and then the acoustic signal generated by the piezoelectric transducer. The signal from the sensor has minimal variation with temperature and static pressure, the frequency of the signal provided by the oscillator is stable in relation to environmental parameters.

INSTRUMENT STORAGE

Storage conditions of the instrument:

- Temperature: -25 ... +55 °C.
- Humidity: less than 90% RH non-condensing.

- Do not store where:
 - The humidity is high.
 - The instrument is exposed to direct sun radiation.
 - The instrument is exposed to a source of high temperature.
 - There are strong vibrations.
 - There is pressure, salt and / or corrosive gas.

The instrument body is ABS plastic: do not use incompatible solvents for clearing.

NOTES ON THE OPERATION AND OPERATIONAL SAFETY

Authorized use

Observe the specifications given in chapter "SPECIFICATIONS". It only authorizes the use and operation in accordance with the instructions in this operating manual. Any other use is considered unauthorized.

General Safety Instructions

This instrument was manufactured and tested according to EN 61010-1 safety standards relating to electronic measuring instruments and left the factory in perfect condition safety techniques. The smooth functioning and operational safety of the instrument can only be guaranteed if you look all normal security measures as well as those specifications described in this manual. The smooth functioning and operational safety of the instrument can be guaranteed only under conditions specified in "Technical Specifications".

Do not use or store the instrument in the manner and / or where are present:

- Rapid changes in temperature that may cause condensation.
- Corrosive or flammable.
- Direct vibration or shock to the instrument.
- High intensity electromagnetic fields, static electricity.

If the instrument is transported from a cold to a warm place, condensation may cause it to function. In this case we expect that the temperature of the instrument to reach room temperature before putting it back on.

User requirements

The user of the instrument must ensure that compliance with the following rules and guidelines concerning the treatment of hazardous materials:

- EC directives on occupational safety
- National laws and safety at work
- Accident prevention regulations

TECHNICAL SPECIFICATIONS

The calibrator HD 2020 falls in the characteristics of **class 1 according to IEC 60942-2003 and meets the requirements of the ANSI S1.40-1984.**

Coupling cavity:	for standard 1/2" microphones (12.7 ±0.03 mm) according to IEC 61094-1 and IEC 61094-4
Frequency:	1000 Hz
Frequency tolerance:	1% in the range -10...+50°C and 10%...90%RH
Sound pressure level:	94.0 dB and 114.0 dB ±0.2 dB at 1 kHz (referred to 101.3 kPa, 23°C ±3°C and 65%R.H.)
Reference conditions:	20°C, 50% RH, 101.3kPa, 10 mm ³ cartridge volume
Stabilization time:	10s
Total distortion:	<1%
Ambient condition influence	
- Temperature and humidity influence:	< 0.3 dB in the range -10°C...50°C and 10%...90%RH
- Static pressure influence:	< 0.1 dB in the range 65 kPa ... 108 kPa
Stability levels	
- Short-term stability:	±0.03 dB
- Stability after 1 year, normal use:	±0.1 dB
Operating conditions	
- Working temperature:	-10 ... +50°C
- Relative humidity:	≤90% R.H.
Storage temperature:	-25 ... +70°C
Microphone equivalent volume:	5 to 250 mm ³
Power supply:	9V alkaline battery IEC type 6LR61. 9V rechargeable batteries are also allowed.
9V battery autonomy:	48-hour continuous functioning with good quality alkaline batteries.
Automatic power off:	5 minutes – it cannot be disabled
Display	3½ LCD, battery symbol
Watch/date-indicator:	internal with 3V lithium buffer battery
Case material:	ABS
Dimensions:	53x43x83mm
Weight:	160g.
IP Protection degree	IP64
Effects of electromagnetic fields:	< 0.3 dB

ORDERING CODES

HD2020: The kit consists of: HD2020 calibrator, 1x 9V alkaline battery, instruction manual. ACCREDIA individual calibration certification included.

Архангельск (8182)63-90-72	Ижевск (3412)26-03-58	Магнитогорск (3519)55-03-13	Пермь (342)205-81-47	Сургут (3462)77-98-35
Астана (7172)727-132	Иркутск (395)279-98-46	Москва (495)268-04-70	Ростов-на-Дону (863)308-18-15	Тверь (4822)63-31-35
Астрахань (8512)99-46-04	Казань (843)206-01-48	Мурманск (8152)59-64-93	Рязань (4912)46-61-64	Томск (3822)98-41-53
Барнаул (3852)73-04-60	Калининград (4012)72-03-81	Набережные Челны (8552)20-53-41	Самара (846)206-03-16	Тула (4872)74-02-29
Белгород (4722)40-23-64	Калуга (4842)92-23-67	Нижний Новгород (831)429-08-12	Санкт-Петербург (812)309-46-40	Тюмень (3452)66-21-18
Брянск (4832)59-03-52	Кемерово (3842)65-04-62	Новокузнецк (3843)20-46-81	Саратов (845)249-38-78	Ульяновск (8422)24-23-59
Владивосток (423)249-28-31	Киров (8332)68-02-04	Новосибирск (383)227-86-73	Севастополь (8692)22-31-93	Уфа (347)229-48-12
Волгоград (844)278-03-48	Краснодар (861)203-40-90	Омск (3812)21-46-40	Симферополь (3652)67-13-56	Хабаровск (4212)92-98-04
Вологда (8172)26-41-59	Красноярск (391)204-63-61	Орел (4862)44-53-42	Смоленск (4812)29-41-54	Челябинск (351)202-03-61
Воронеж (473)204-51-73	Курск (4712)77-13-04	Оренбург (3532)37-68-04	Сочи (862)225-72-31	Череповец (8202)49-02-64
Екатеринбург (343)384-55-89	Липецк (4742)52-20-81	Пенза (8412)22-31-16	Ставрополь (8652)20-65-13	Ярославль (4852)69-52-93
Иваново (4932)77-34-06	Киргизия (996)312-96-26-47	Казахстан (772)734-952-31	Таджикистан (992)427-82-92-69	

Единый адрес для всех регионов: dmh@nt-rt.ru || www.deltaohm.nt-rt.ru