

# Контроллеры (преобразователи) проводимости DELTA OHM DO9786T-R, DO9766T-R1

## Технические характеристики

Архангельск (8182)63-90-72  
Астана (7172)727-132  
Астрахань (8512)99-46-04  
Барнаул (3852)73-04-60  
Белгород (4722)40-23-64  
Брянск (4832)59-03-52  
Владивосток (423)249-28-31  
Волгоград (844)278-03-48  
Вологда (8172)26-41-59  
Воронеж (473)204-51-73  
Екатеринбург (343)384-55-89  
Иваново (4932)77-34-06

Ижевск (3412)26-03-58  
Иркутск (395)279-98-46  
Казань (843)206-01-48  
Калининград (4012)72-03-81  
Калуга (4842)92-23-67  
Кемерово (3842)65-04-62  
Киров (8332)68-02-04  
Краснодар (861)203-40-90  
Красноярск (391)204-63-61  
Курск (4712)77-13-04  
Липецк (4742)52-20-81  
Киргизия (996)312-96-26-47

Магнитогорск (3519)55-03-13  
Москва (495)268-04-70  
Мурманск (8152)59-64-93  
Набережные Челны (8552)20-53-41  
Нижний Новгород (831)429-08-12  
Новокузнецк (3843)20-46-81  
Новосибирск (383)227-86-73  
Омск (3812)21-46-40  
Орел (4862)44-53-42  
Оренбург (3532)37-68-04  
Пенза (8412)22-31-16  
Казахстан (772)734-952-31

Пермь (342)205-81-47  
Ростов-на-Дону (863)308-18-15  
Рязань (4912)46-61-64  
Самара (846)206-03-16  
Санкт-Петербург (812)309-46-40  
Саратов (845)249-38-78  
Севастополь (8692)22-31-93  
Симферополь (3652)67-13-56  
Смоленск (4812)29-41-54  
Сочи (862)225-72-31  
Ставрополь (8652)20-65-13  
Таджикистан (992)427-82-92-69

Сургут (3462)77-98-35  
Тверь (4822)63-31-35  
Томск (3822)98-41-53  
Тула (4872)74-02-29  
Тюмень (3452)66-21-18  
Ульяновск (8422)24-23-59  
Уфа (347)229-48-12  
Хабаровск (4212)92-98-04  
Челябинск (351)202-03-61  
Череповец (8202)49-02-64  
Ярославль (4852)69-52-93

Единый адрес для всех регионов: [dmh@nt-rt.ru](mailto:dmh@nt-rt.ru) || [www.deltaohm.nt-rt.ru](http://www.deltaohm.nt-rt.ru)

## D09786T-R; D09766T-R1



## D09786T-R1; D09766T-R1 CONDUCTIVITY TRANSMITTERS

**D09786T / D09766T** transmitters convert the output of a conductivity electrode with temperature compensation into a 4÷20 mA signal.

The electrode input circuit is galvanically insulated against the 4÷20 mA output signal. An LCD indicator allows viewing of the process signal value and of the various parameters. The accurate design and choice of components make the instrument precise and reliable for a long working life.

The instrument works in conjunction with a conductivity electrode and a temperature probe (Pt100 sensor, 100 Ω at 0°C).

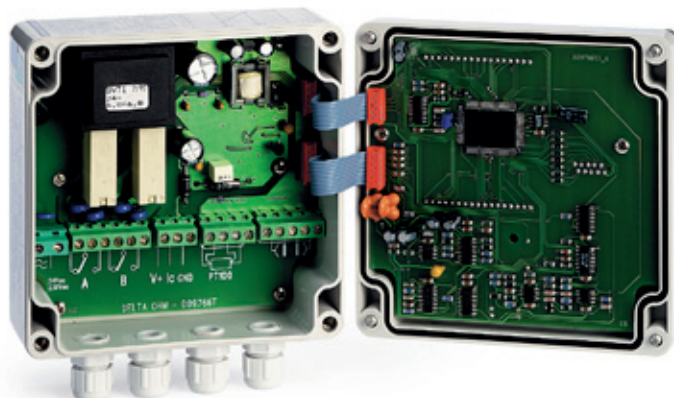

### Technical characteristics

Input conductivity	Measuring range	0.0...199.9 mS
	2/4 electrodes	Configurable cell constant 0.01...199.9 cm <sup>-1</sup>
	Transducer energizing	Square wave 10...1000 mV, depending on conductivity, 200...1600 Hz, depending on conductivity
	Input impedance	>100 MΩ
	Cable length	<10 metres unshielded <50 metres screened (about 2 nF)
	Accuracy	0.5% of reading ±2 digits ±0.01% per °C of drift in temperature
Input temperature	Pt100 2/4 wires	-50...199.9°C
	Transducer energizing	0.5 mA dc
	Cable length	<10 metres unshielded <50 metres screened (about 5 nF)
	Accuracy	0.2°C ±0.1% of reading ±0.01°C/°C of drift in temperature
Compensation temperature	None	
	manual	Linear 0.00...4.00%/°C -50...+200°C
	automatic	Linear 0.00...4.00%/°C -50...+200°C
	Reference temperature	20 or 25°C Configurable
Current output	4.00...20.00 mA	Programmable and proportional to conductivity
	Accuracy	0.5% of reading ±0.02 mA
	Insulation	2500 Vac 1 minute
R Load	Load resistance	$R_{Lmax} = \frac{V_{dc}-10}{0,022}$ $R_{Lmax} = 636 \Omega @ V_{dc} = 24 V_{dc}$
	Relay output	A and B Bistable, contact 3A/230 Vac free potential
Power supply	Passive	4÷20 mA, 2 wire configuration, 10÷35 V, see fig. 2
	Active	24/230 Vac - 15/+10% 1 VA, 48...62 Hz, see fig. 1
Case DO 9766T	External dimensions	120x122x56 mm wall mounting
	Protection class	IP64
Case DO 9786T	External dimensions	96x96x126 mm panel mounting
	Protection class	IP44

### Key functions

**PRG** Programming of the parameters is activated by pressing the PRG key plus the ▲ and ▼ keys. The message P1 appears on the display, indicating that the parameter P1 is being programmed. When the PRG key is pressed continuously, the messages P2, P3, P4, P5, P6, P7, P8 and the corresponding parameters are displayed in sequence. After P8 the instrument returns to normal function.

**SET** Key for setting the relay intervention threshold. The ON or OFF symbol appears on the display, indicating the switching on or off threshold of relay A or of relay B.

**°C/°F** - If this key is pressed it changes the temperature measuring unit to degrees Celsius or degrees Fahrenheit.

- When pressed together with the CAL key it activates the manual temperature setting function.  
- If pressed during the conductivity calibration function it quits the calibration function without storing the calibration.

**X** When pressed together with the CAL key it activates the conductivity calibration function.

**OK** Confirms the programming parameters, or the relay SET values, and stores them.

**CAL** - When pressed together with the °C/°F key it activates the manual temperature setting function.  
- When pressed together with the X key it activates the conductivity calibration function.  
- Key used to confirm conductivity calibration and manual temperature calibration.

▲ - Key for increasing the value displayed in the parameter programming phase.  
- During the relay SET point programming phase.  
- During the calibration phase.

▼ - Key for decreasing the value displayed in the parameter programming phase.  
- During the relay SET point programming phase.  
- During the calibration phase.

### Setting the relay SET point

- Press the SET button; the ON symbol appears on the display with the letter A to indicate that the value shown corresponds to the switching on threshold of relay A.
- To change this value press the ▲ and ▼ keys.
- Press SET; the OFF symbol appears with the letter A to indicate that the switching off threshold of relay A is being displayed.
- To change this value press the ▲ and ▼ keys.
- Press the SET button; the ON symbol appears on the display with the letter B to indicate that the value shown corresponds to the switching on threshold of relay B.
- To change this value press the ▲ and ▼ keys.
- Press SET; the OFF symbol appears with the letter B to indicate that the switching off threshold of relay B is being displayed.
- To change this value press the ▲ and ▼ keys.
- Press SET, the instrument stores the values and returns to normal function.

**NOTE:** During the SET point setting phase (symbols ON or OFF lit) the instrument returns to normal function if no key is pressed for 2 minutes.

### Manual temperature setting

If the temperature probe is not connected or if the probe is broken the measuring unit °C or °F flashes. In this case it is possible to set the temperature compensation value manually.

- Press the CAL key and the °C/°F key together; the message CAL appears at the bottom of the display.
- Using the ▲ and ▼ keys, set the temperature value corresponding to the temperature of the liquid in which you wish to measure conductivity.
- Press CAL to confirm this value. The message CAL disappears.

### Calibration of the DO 9786T-R1 / DO 9766T-R1 with conductivity probes

Calibration of the DO 9786T-R1 / DO 9766T-R1 transmitters with conductivity probes:

- Immerse the probe in the buffer solution used for calibration.
- Press the CAL key and the X key together; the message CAL appears at the top of the display.
- The instrument can automatically recognize two standard calibration solutions: a 0.1 molar solution of KCl and a 0.01 molar solution of KCl. The instrument proposes the conductivity value as a function of the measured temperature if the temperature probe is connected, or the manually set temperature.
- Using the ▲ and ▼ keys, adjust the conductivity value measured as a function of the liquid temperature.
- Press CAL to confirm this value. The message CAL disappears.

**NOTE:** If you want to quit without storing the new calibration, press the °C/°F key.

**N.B.:** Before calibrating the probe set a cell constant close to the cell constant of the probe that you wish to calibrate with key PRG, function P2. If the message E1 appears during calibration, the instrument is indicating that the probe gain is too high; quit programming (°C/°F button) and increase the value of the cell constant. Likewise, if E2 appears, the instrument is indicating that the probe gain is too low; quit calibration and decrease the cell constant. Repeat the calibration operation.

### Programming the parameters

- P1 Temperature coefficient. May be set between 0 and 4.00%/°C (0 and 2.22%/°F).
- P2 Cell constant. May be set between 0.01 and 199.9.
- P3 Conductivity value corresponding to 4 mA at output. May be set between 0 and 199.9 mS.
- P4 Conductivity value corresponding to 20 mA at output. May be set between 0 and 199.9 mS.
- P5 Delay time in the intervention of relay A. May be set between 0 and 250 seconds.
- P6 Delay time in the intervention of relay B. May be set between 0 and 250 seconds.
- P7 Reference temperature of the conductivity measurement. May be set between the values 20.0 or 25.0°C.
- P8 Calibration of Pt100 probe and calibration of analog output in current (see Pt100 probe calibration and analog output calibration).

To change one of these parameters (except P8) press key PRG until the message corresponding to the parameter to be changed appears on the screen. Using the ▲ and ▼ keys, bring the parameter displayed to the desired value. Press OK to confirm.

### Pt100 probe calibration

(Factory calibration to be performed by skilled workers)

- Connect the Pt100 probe to the instrument. Press the PRG key until the message P8 appears on the display.
- Press the CAL key; the message CAL appears at the bottom of the display and the temperature is shown at the top.
- Immerse the Pt100 probe and a precision thermometer for reference in the zero calibration bath. Wait long enough for the reading to become stable.
- Using the ▲ and ▼ keys, adjust the value of the temperature measured by the Pt100 probe so that it corresponds with the value on the reference thermometer.
- Immerse the Pt100 probe and a precision thermometer in the full scale calibration bath. Wait long enough for the reading to become stable.
- Using the ▲ and ▼ keys, adjust the value of the temperature measured by the Pt100 probe so that it corresponds with the value on the reference thermometer.
- Press OK to confirm.

**N.B.:** If the temperature shown by the instrument is between +12°C, the instrument calibrates the probe offset, otherwise it calibrates the gain.

### Calibrating the analog output

(Factory calibration to be performed by skilled workers)

- Press the PRG key until the message P8 appears on the display.
- Connect a precision milliammeter to the analog output.
- Press the CAL key twice; the message CAL appears at the top of the display and the message 4.0 at the bottom, indicating calibration at 4 mA.
- Using the ▲ and ▼ keys, adjust the value of the output current so as to have an indication of 4,000 mA on the precision milliammeter.
- Press the CAL key; the message CAL appears at the top of the display and the message 20.0 at the bottom, indicating calibration at 20 mA.
- Using the ▲ and ▼ keys, adjust the value of the output current so as to have an indication of 20,000 mA on the precision milliammeter.
- Press OK to confirm.

### Display

#### Symbol Description

- °C indicates that the value shown is in °C.
- °F indicates that the value shown is in °F.
- µS indicates that the unit of the value shown is micro Siemens.
- mS indicates that the unit of the value shown is milli Siemens.
- A indicates that the relay A is in closed status.
- B indicates that the relay B is in closed status.
- ON indicates that the value shown corresponds to the closing thresholds of the contacts of relay A or B.
- OFF indicates that the value shown corresponds to the opening thresholds of the contacts of relay A or B.

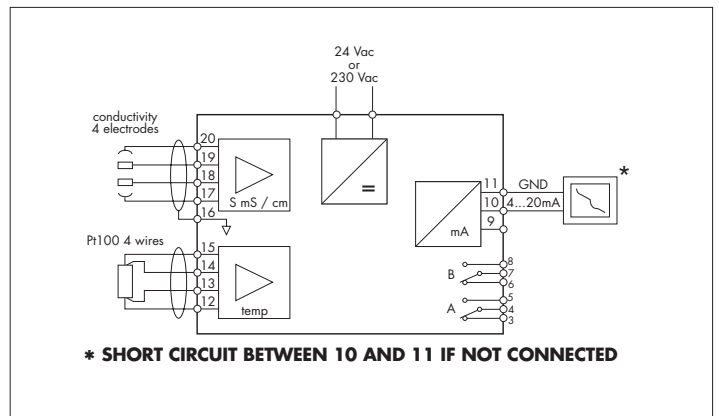

Fig.1 Active transmitter.

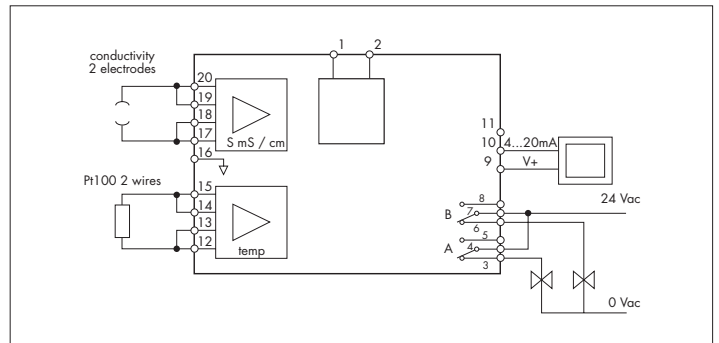

Fig.2 Passive transmitter.

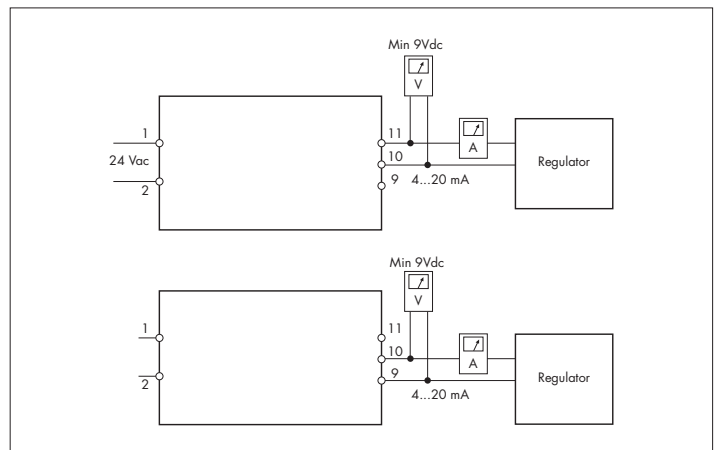
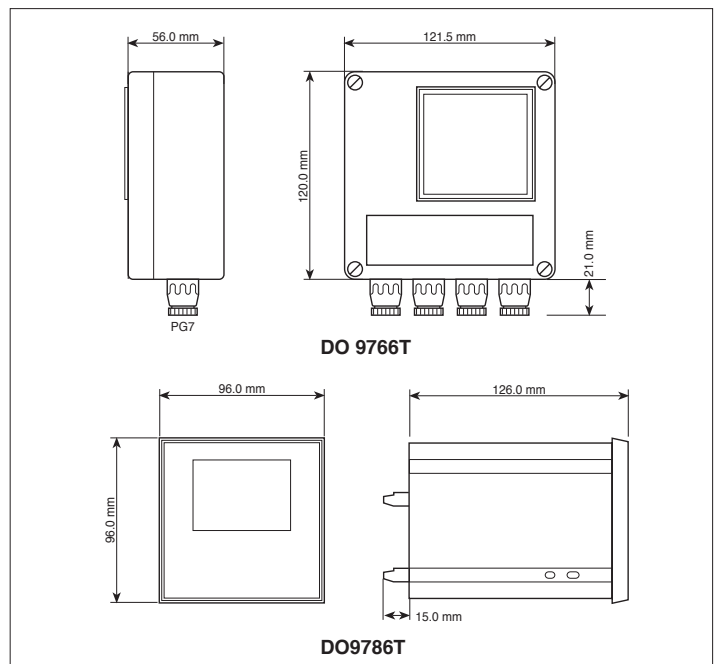

Fig.3 Calibration analog output.



Dimensions

## Error signals

- OFL** - Warning which appears during measurement when the value to be displayed is out of scale.
- E1** - Error warning which appears during conductivity calibration to indicate that the probe gain is too high. Press P2 to increase the cell constant value.
- E2** - Error warning which appears during conductivity calibration to indicate that the probe gain is too low. Press P2 to decrease the cell constant value.
- E3** - Error warning which appears to indicate that the instrument is unable to recognize the buffer solution used for automatic calibration. Press the ▲ or ▼ key to make this indication disappear.
- E4** - Reading error on the EEPROM.

## APPENDIX

### Table of compatibility between range and sensor

Conductivity Range	Nominal cell constant			
	0.01÷0.2	0.2÷2	2÷20	20÷199.9
0÷19.99 µS	√			
0÷199.9 µS	√	√		
0÷1999 µS	√	√	√	
0÷199.9 mS	√	√	√	√
0÷19.99 mS		√	√	√
0÷199.9 mS			√	√
0÷1999 mS				√

### Temperature sensor

Temperature	Pt100	Temperature	Pt100
-50°C	80.25 Ω	100°C	138.50 Ω
-25°C	90.15 Ω	125°C	147.94 Ω
0°C	100.00 Ω	150°C	157.32 Ω
25°C	109.73 Ω	175°C	166.62 Ω
50°C	119.40 Ω	199°C	175.47 Ω
75°C	128.98 Ω		

### Calculating the temperature coefficient of a solution

If the temperature coefficient of the solution is not known, it may be determined using the DO 9786T/DO 9766T.

- Set the temperature coefficient at 0.0%/°C (parameter P1).
- The following measurements should be taken as close as possible to the work point, between 5°C and 70°C, for greater accuracy.
- Immerse the probe in the testing liquid. Wait for the measurement to become stable.
  - Take note of the temperature and of the conductivity.
  - Increase the solution temperature by at least 10°C.
  - Take note of the temperature and of the conductivity.
  - Calculate the temperature coefficient using the following formula:

$$\alpha = \frac{(G_x - G_y) \times 100\%}{G_y(T_x - 20) - G_x(T_y - 20)} \quad (\text{reference temperature } 20^\circ\text{C})$$

Where:

G<sub>x</sub> conductivity at temperature T<sub>x</sub>  
G<sub>y</sub> conductivity at temperature T<sub>y</sub>

**N.B.:** if the reference temperature is 25°C, replace 20 with 25.

- Set the temperature coefficient with the value calculated as above (parameter P1).

### Calibration of the instrument for measuring conductivity

The conductivity measurement depends strongly on the temperature of the liquid that is to be measured; this relationship must be considered during calibration.

### Calibration of the instrument alone by means of a precision resistance

This is a sure and accurate method for calibrating the instrument alone, but it does not allow for the variations of the cell constant that may occur, nor of the state of efficiency and cleanness of the cell.

The precision resistance used for calibration will be chosen according to the scale that you want to calibrate. Typical values are the following:

Conductivity	Resistance
100,0 µS	10.000 Ω
500,0 µS	2.000 Ω
1000 µS	1.000 Ω
5000 µS	200 Ω
10,00 mS	100 Ω
50,00 mS	20 Ω
100,0 mS	10 Ω
500,0 mS	2 Ω
1000 mS	1 Ω

The precision resistance will be connected to the end of the cable that connects the probe to the instrument. This ensures greater accuracy of calibration. Disable the temperature compensation α<sub>T</sub> during the calibration of the instrument with the precision resistances.

## Calibration with standard solutions

In this case too, for the calibration of the instrument, cable and measuring probes in a standard solution, the greatest attention must be paid to the temperature of the solutions and the cleanness of the measuring cell. It is advised not to carry out calibration below 500 µS/cm. Solutions with low conductivity must be kept closed in their containers. Contact with the air increases their value due to the absorption of CO<sub>2</sub>.

The regulations for the preparation of standard solutions with a base of KCl dissolved in water with a high degree of purity supply the method and percentages of KCl and water to be mixed. DELTA OHM supplies four solutions for calibration:

**HD8747:** Standard calibration solution 0.001 mol/l equal to 147 µS/cm @25°C, 200cc.

**HD8714:** Standard calibration solution 0.01 mol/l equal to 1413 µS/cm @25°C, 200cc.

**HD8712:** Standard calibration solution 0.1 mol/l equal to 12880 µS/cm @25°C, 200cc.

**HD87111:** Standard calibration solution 1 mol/l equal to 111800 µS/cm @25°C, 200cc.

## Care and maintenance of the conductivity cell

In conductivity measurement systems in industrial plants, if the installation is correctly made, readings are generally reliable for a long time. The important thing is to carry out correct, programmed maintenance of the measuring cell.

Abrasion of the cable due to continued swinging movements must be avoided, as must the formation of deposits and scale on the cell which can change its geometrical structure.

The cell must always be immersed in the liquid that is to be measured. In the industrial field, measurements may range from highly pure water to sewage or water contaminated by corrosive substances.

It is good practice to check the compatibility of the materials of which the cell and the connecting cable are made with the liquid in which the measurement is to be taken. Check that there are no floating bodies, suspended granules that may be more or less conductive, or which could get stuck inside the cell, thus leading to incorrect measurements.

To clean the cell use detergents or substances suitable for the material of which the cell is made.

## Selecting the cell constant and installation

The measurement range of the liquid to be examined determines the choice of the cell constant to be used.

Installation of the cell will vary according to the application. On the whole, the following points must be considered:

- Choose the correct cell and cell constant, suitable for the application.
- Use suitable materials, cable, cell, supports, so as to resist corrosion and the influence of atmospheric agents.
- The sensor/cell must be firmly fixed, in a place where they are easily accessible for maintenance.
- The liquid in which the sensor is immersed must be a representative part of the whole that is to be measured.
- There must be a moderate flow of liquid so that an updated sample of liquid arrives at the electrodes. Excessive movement or flow causes turbulence and air bubbles between the electrodes. As an air bubble is not conductive, it modifies the volume of the cell and changes the constant.
- Install the sensor in such a way that sludge or particles of material cannot be deposited inside it.
- If installed in containers where high currents are circulating, the conductivity cell may present measuring problems.
- The maintenance and cleaning interval depends on the quality of the liquid in which the cell is installed.

## ORDER CODE

**DO986T-R1:** Conductivity transmitter 4÷20 mA passive or active, power supply 24 Vac with double display 96x96 mm, **for panel mounting.**

**DO9766T-R1:** Conductivity transmitter 4÷20 mA passive or active, power supply 24 Vac with double display 122x120 mm, **for use on the field.**

**SPT 86:** Combined industrial conductivity and temperature probe in POCAN with 4 platinum electrodes, cell constant K = 0.7, 1.5 meters cable, Pt100 with 4 wires. Temperature 0÷90°C.

**SPTKI 10:** Combined industrial conductivity probe in Glass with 2 platinum electrodes, cell constant K = 1, **S7/PG13** screw-joint, 2 wires output: eurostandard S7. Temperature 0÷100°C.

**SPTKI 11:** Combined industrial conductivity and temperature probe in Rytron with 2 electrodes, cell constant K = 1, 5 meters cable, Pt100 with four wires. Temperature 0÷80°C.

**SPTKI 12:** Combined industrial conductivity and temperature probe in Rytron with 2 platinum electrodes, cell constant K = 01, 5 meters cable, Pt100 with four wires. Temperature 0÷80°C.

**SPTKI 13:** Combined industrial conductivity and temperature probe in Rytron with 2 platinum electrodes, cell constant K = 10, 5 meters cable, Pt100 with four wires. Temperature 0÷80°C.

**SPT 401.001:** Combined conductivity and temperature probe with 2-electrode in AISI316 stainless steel, cell constant 0.01. Measuring range 0.04 ... 20 µS, 0 ... 120 °C.

**HD 882 M100/300:** Temperature probe with Pt100 sensor, miniature head, shaft Ø6x300 mm.

**HD 882 M100/600:** Temperature probe with Pt100 sensor, miniature head, shaft Ø6x600 mm.

**HD 8747:** Calibration solution 0.001 mol/l corresponding to 147 µS/cm at 25°C, 200cc.

**HD 8712:** Calibration solution 0.1 mol/l corresponding to 12880 µS/cm at 25°C, 200cc.

**HD 8714:** Calibration solution 0.01 mol/l corresponding to 1413 µS/cm at 25°C, 200cc.

**HD 87111:** Calibration solution 1 mol/l corresponding to 111800 µS/cm at 25°C, 200cc.

**CP 5T:** Extension cable to connect the probe SPT KI 10 to the transmitter, L=5m (S7 on one side, wires on the other side)

**CP 5/10T:** Extension cable to connect the probe SPT KI 10 to the transmitter, L=10m (S7 on one side, wires on the other side)

**CP 5/20T:** Extension cable to connect the probe SPT KI 10 to the transmitter, L=20m (S7 on one side, wires on the other side)

**SPT 401.001**  
cell constant K=0.01

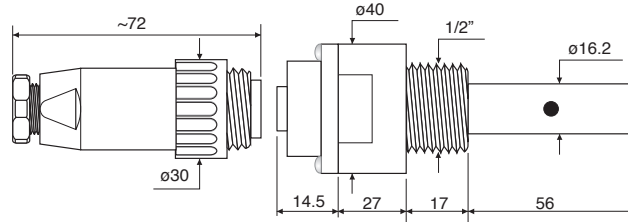

**SPT 86**  
cell constant K=0.7

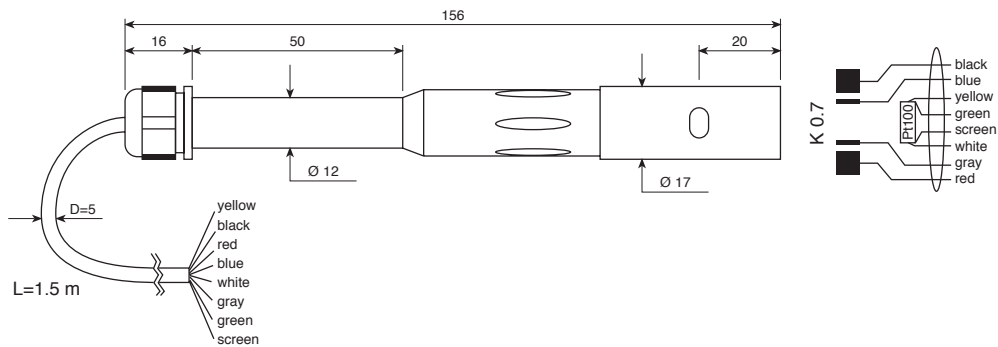

**SPTKI 10**  
cell constant K=1

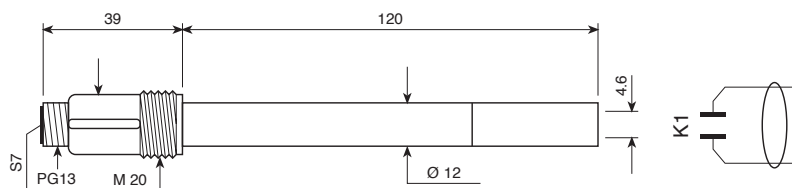

**SPTKI 11**  
cell constant K=1

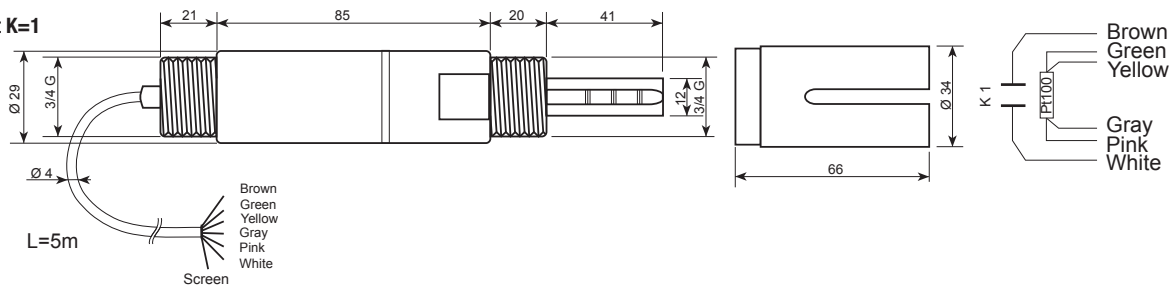

**SPTKI 12**  
cell constant K=0.1

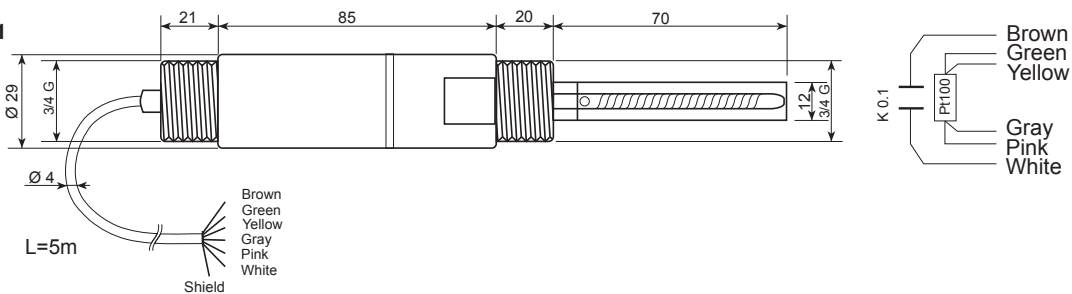

**SPTKI 13**  
cell constant K=10

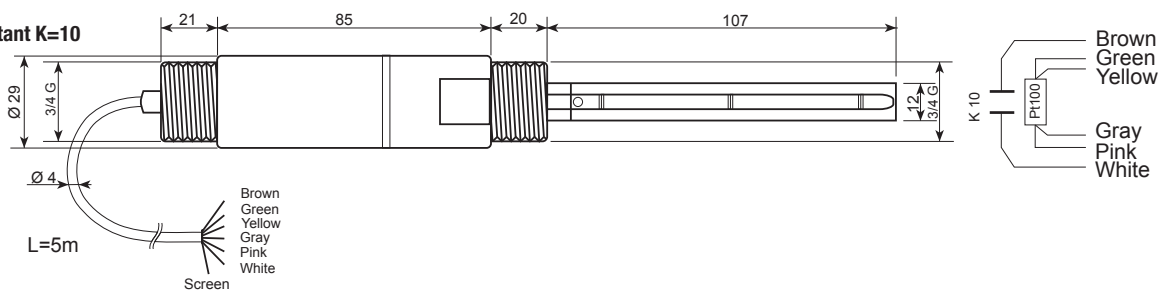

	Cell constant	Measuring range	Temperature range	Material	Electrodes	Temperature sensor	Max. pressure	Connection
<b>SPT 401.001</b>	K=0.01	0.04÷20µS/cm	0÷120°C	AISI 316 - PTFE	2 AISI 316	-	12bar	4-pole connector
<b>SPT 86</b>	K=0.7	5µS÷20mS	0÷90°C	Pocan	4 platinum	Pt100 4 wire	6bar	1.5 m cable
<b>SPTKI 10</b>	K=1	100µS÷200mS	0÷100°C	Glass	2 platinum	-	6bar	S7
<b>SPTKI 11</b>	K=1	100µS÷10mS	0÷80°C	Rytron	2 platinum	Pt100 4 wire	6bar	5 m cable
<b>SPTKI 12</b>	K=0.1	1µS÷1mS	0÷80°C	Rytron	2 platinum	Pt100 4 wire	6bar	5 m cable
<b>SPTKI 13</b>	K=10	10µS÷200mS	0÷80°C	Rytron	2 platinum	Pt100 4 wire	6bar	5 m cable

<b>Архангельск</b> (8182)63-90-72	<b>Ижевск</b> (3412)26-03-58	<b>Магнитогорск</b> (3519)55-03-13	<b>Пермь</b> (342)205-81-47	<b>Сургут</b> (3462)77-98-35
<b>Астана</b> (7172)727-132	<b>Иркутск</b> (395)279-98-46	<b>Москва</b> (495)268-04-70	<b>Ростов-на-Дону</b> (863)308-18-15	<b>Тверь</b> (4822)63-31-35
<b>Астрахань</b> (8512)99-46-04	<b>Казань</b> (843)206-01-48	<b>Мурманск</b> (8152)59-64-93	<b>Рязань</b> (4912)46-61-64	<b>Томск</b> (3822)98-41-53
<b>Барнаул</b> (3852)73-04-60	<b>Калининград</b> (4012)72-03-81	<b>Набережные Челны</b> (8552)20-53-41	<b>Самара</b> (846)206-03-16	<b>Тула</b> (4872)74-02-29
<b>Белгород</b> (4722)40-23-64	<b>Калуга</b> (4842)92-23-67	<b>Нижний Новгород</b> (831)429-08-12	<b>Санкт-Петербург</b> (812)309-46-40	<b>Тюмень</b> (3452)66-21-18
<b>Брянск</b> (4832)59-03-52	<b>Кемерово</b> (3842)65-04-62	<b>Новокузнецк</b> (3843)20-46-81	<b>Саратов</b> (845)249-38-78	<b>Ульяновск</b> (8422)24-23-59
<b>Владивосток</b> (423)249-28-31	<b>Киров</b> (8332)68-02-04	<b>Новосибирск</b> (383)227-86-73	<b>Севастополь</b> (8692)22-31-93	<b>Уфа</b> (347)229-48-12
<b>Волгоград</b> (844)278-03-48	<b>Краснодар</b> (861)203-40-90	<b>Омск</b> (3812)21-46-40	<b>Симферополь</b> (3652)67-13-56	<b>Хабаровск</b> (4212)92-98-04
<b>Вологда</b> (8172)26-41-59	<b>Красноярск</b> (391)204-63-61	<b>Орел</b> (4862)44-53-42	<b>Смоленск</b> (4812)29-41-54	<b>Челябинск</b> (351)202-03-61
<b>Воронеж</b> (473)204-51-73	<b>Курск</b> (4712)77-13-04	<b>Оренбург</b> (3532)37-68-04	<b>Сочи</b> (862)225-72-31	<b>Череповец</b> (8202)49-02-64
<b>Екатеринбург</b> (343)384-55-89	<b>Липецк</b> (4742)52-20-81	<b>Пенза</b> (8412)22-31-16	<b>Ставрополь</b> (8652)20-65-13	<b>Ярославль</b> (4852)69-52-93
<b>Иваново</b> (4932)77-34-06	<b>Киргизия</b> (996)312-96-26-47	<b>Казахстан</b> (772)734-952-31	<b>Таджикистан</b> (992)427-82-92-69	

**Единый адрес для всех регионов: [dmh@nt-rt.ru](mailto:dmh@nt-rt.ru) || [www.deltaohm.nt-rt.ru](http://www.deltaohm.nt-rt.ru)**